

FRONT & REAR AXLE

SECTION **AX**

CONTENTS

FRONT AXLE	2	COMPONENTS	18
Precautions	2	REMOVAL.....	19
PRECAUTIONS	2	DISASSEMBLY.....	20
Preparation	2	INSPECTION.....	21
SPECIAL SERVICE TOOLS	2	ASSEMBLY	21
COMMERCIAL SERVICE TOOLS.....	3	INSTALLATION.....	23
Noise, Vibration and Harshness (NVH)		Service Data and Specifications (SDS).....	25
Troubleshooting	4	WHEEL BEARING (FRONT)	25
NVH TROUBLESHOOTING CHART	4	DRIVE SHAFT (4WD MODELS).....	25
On-vehicle Service.....	4	REAR AXLE	27
FRONT AXLE PARTS	4	Precautions	27
FRONT WHEEL BEARING	5	PRECAUTIONS	27
DRIVE SHAFT	7	Preparation	27
Components.....	8	SPECIAL SERVICE TOOLS	27
Manual-lock Free-running Hub	10	COMMERCIAL SERVICE TOOLS.....	27
DESCRIPTION	10	Noise, Vibration and Harshness (NVH)	
REMOVAL AND INSTALLATION.....	10	Troubleshooting	29
INSPECTION.....	11	On-vehicle Service.....	29
Auto-lock Free-running Hub	11	REAR AXLE PARTS.....	29
DESCRIPTION	11	REAR WHEEL BEARING	30
REMOVAL AND INSTALLATION.....	12	Components.....	31
INSPECTION.....	13	Removal.....	32
TROUBLE DIAGNOSIS FOR NOISE	13	Inspection.....	34
Wheel Hub and Rotor Disc.....	14	AXLE SHAFT.....	34
REMOVAL AND INSTALLATION.....	14	WHEEL BEARING	34
DISASSEMBLY.....	15	AXLE CASE	34
INSPECTION.....	15	Installation.....	34
ASSEMBLY	15	2WD MODELS.....	34
Knuckle Spindle	16	4WD MODELS.....	36
REMOVAL.....	16	Service Data and Specifications (SDS).....	38
INSPECTION.....	17	WHEEL BEARING (REAR)	38
INSTALLATION.....	18		
Drive Shaft.....	18		

GI
MA
EM
LC
EC
FE
CL
MT
AT
TF
PD
AX
SU
BR
ST
RS
BT
HA
SC
EL
IDX

FRONT AXLE

Precautions

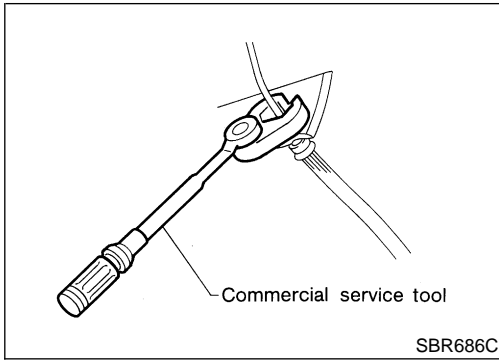

Precautions PRECAUTIONS

- When installing rubber parts, final tightening must be carried out under unladen condition* with tires on ground.
*: Fuel, radiator coolant and engine oil full. Spare tire, jack, hand tools and mats in designated positions.
- Use flare nut wrench when removing and installing brake tubes.
- After installing removed suspension parts, check wheel alignment and adjust if necessary.
- Always torque brake lines when installing.

CAUTION:

- The ZF100 (wheel side) type joint assembly has two types of boot material; one is made of rubber and the other is made of plastic.
- Do not disassemble the joint assembly with the plastic boot. If the boot or joint is damaged, replace the drive shaft assembly.

Preparation

SPECIAL SERVICE TOOLS

The actual shapes of Kent-Moore tools may differ from those of special service tools illustrated here.

NGAX0002

Tool number (Kent-Moore No.) Tool name	Description
ST29020001 (J24319-01) Gear arm puller	<p>Removing ball joint for knuckle spindle a: 34 mm (1.34 in) b: 6.5 mm (0.256 in) c: 61.5 mm (2.421 in)</p> <p>NT694</p>
HT72520000 (J25730-B) Ball joint remover	<p>Removing tie-rod outer end and lower ball joint a: 33 mm (1.30 in) b: 50 mm (1.97 in) r: R11.5 mm (0.453 in)</p> <p>NT546</p>
KV401021S0 () Bearing race drift	<p>Installing wheel bearing outer race</p> <p>NT153</p>

FRONT AXLE

Preparation (Cont'd)

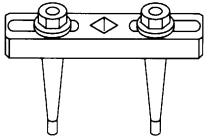
Tool number (Kent-Moore No.) Tool name	Description	
KV40105400 (J36001) Wheel bearing lock nut wrench		Removing and installing wheel bearing lock nut (4WD models only)
	NT154	

COMMERCIAL SERVICE TOOLS

NGAX0003

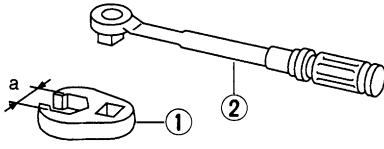
Tool name	Description	
1 Flare nut crowfoot 2 Torque wrench		Removing and installing each brake piping a: 10 mm (0.39 in)
	NT360	

GI

MA

EM

LC

EC

FE

CL

MT

AT

TF

PD

AX

SU

BR

ST

RS

BT

HA

SC

EL

IDX

FRONT AXLE

Noise, Vibration and Harshness (NVH) Troubleshooting

Noise, Vibration and Harshness (NVH) Troubleshooting

=NGAX0004

NVH TROUBLESHOOTING CHART

NGAX0004S01

Use the chart below to help you find the cause of the symptom. If necessary, repair or replace these parts.

Reference page			—	AX-21	—	AX-8, 31	—	AX-5, 30	NVH, PD-4	NVH, PD-4	Refer to DRIVE SHAFT in this chart.	Refer to AXLE in this chart.	NVH, SU-3	NVH, SU-3	NVH, SU-3	NVH, BR-5	NVH, ST-5	
Possible cause and SUSPECTED PARTS			Excessive joint angle	Joint sliding resistance	Imbalance	Improper installation, looseness	Parts interference	Wheel bearing damage	PROPELLER SHAFT	DIFFERENTIAL	DRIVE SHAFT	AXLE	SUSPENSION	TIRES	ROAD WHEEL	BRAKES	STEERING	
Symptom	DRIVE SHAFT	Noise, Vibration	x	x					x	x		x	x	x	x	x	x	
		Shake	x		x				x			x	x	x	x	x	x	x
	AXLE	Noise				x	x		x	x	x		x	x	x	x	x	x
		Shake				x	x		x		x		x	x	x	x	x	x
		Vibration				x	x		x		x		x	x				x
		Shimmy				x	x						x	x	x	x	x	x
		Judder				x							x	x	x	x	x	x
		Poor quality ride or handling				x	x	x						x	x	x		

x: Applicable

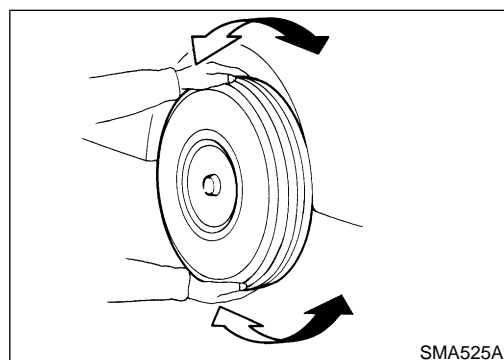

On-vehicle Service FRONT AXLE PARTS

NGAX0005

Check front axle parts for excessive play, cracks, wear and other damage.

- Shake each front wheel to check for excessive play. If looseness is noted, adjust wheel bearing end play, then check ball joint end play.
- Make sure that the cotter pin is inserted.
- Retighten all nuts and bolts to the specified torque.

: Refer to SU-11, "Components".

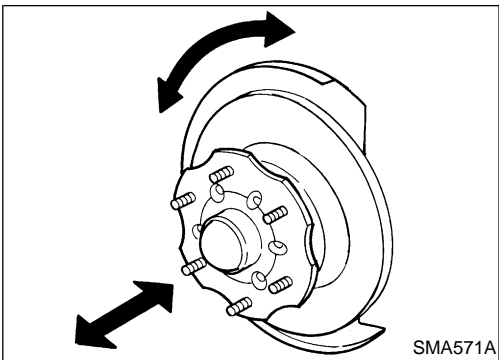

FRONT WHEEL BEARING

NGAX0006

- Check that wheel bearings operate smoothly.
- Check axial end play.
 - Axial end play: 0 mm (0 in)**
- Adjust wheel bearing preload if there is any axial end play or wheel bearing does not turn smoothly.

GI

MA

EM

LC

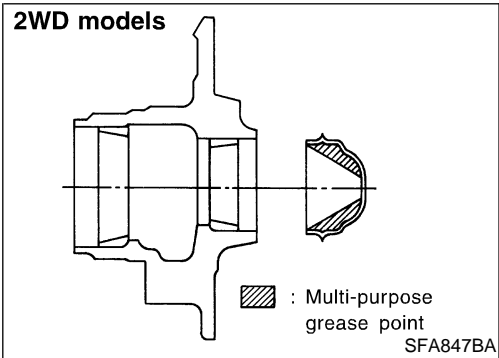

Preload Adjustment (2WD models)

NGAX0006S01

Adjust wheel bearing preload after wheel bearing has been replaced or front axle has been reassembled.

1. Before adjustment, thoroughly clean all parts to prevent dirt entry.
2. Apply multi-purpose grease sparingly to the following parts:
 - Threaded area of spindle
 - Contact surface between lock washer and outer wheel bearing
 - Hub cap (as shown at left) **18 - 22 g (0.63 - 0.78 oz)**
 - Grease seal lip
3. Tighten wheel bearing lock nut to the specified torque.
 - ☞ : 34 - 39 N-m (3.5 - 4.0 kg-m, 25 - 29 ft-lb)**
4. Turn wheel hub several times in both directions to seat wheel bearing correctly.
5. Again tighten wheel bearing lock nut to the specified torque.
 - ☞ : 34 - 39 N-m (3.5 - 4.0 kg-m, 25 - 29 ft-lb)**

EC

FE

CL

MT

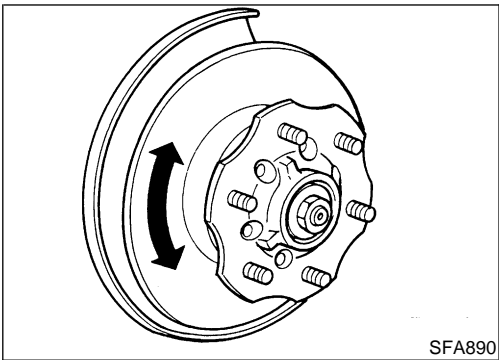

AT

TF

PD

AX

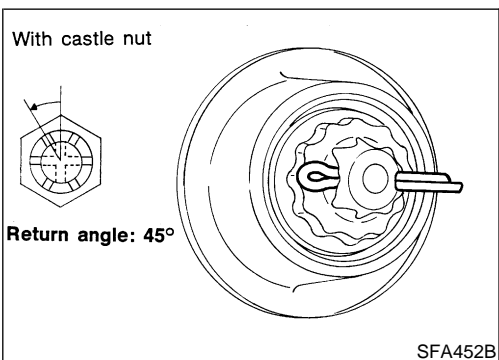

6. Turn wheel bearing lock nut back 45 degrees.
7. Fit adjusting cap and new cotter pin. Align cotter pin slot by loosening nut 15 degrees or less.

SU

BR

ST

RS

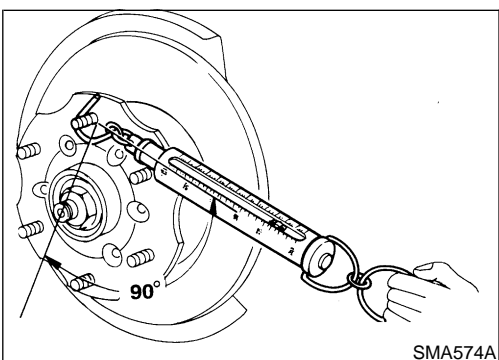

8. Measure wheel bearing preload and axial end play.
 - Axial end play: 0 mm (0 in)**
 - Wheel bearing preload (As measured at wheel hub bolt):**
 - New grease seal**
 - 9.8 - 28.4 N (1.0 - 2.9 kg, 2.2 - 6.4 lb)**
 - Used grease seal**
 - 9.8 - 23.5 N (1.0 - 2.4 kg, 2.2 - 5.3 lb)**

BT

HA

SC

EL

Repeat above procedures until correct bearing preload is obtained.

IDX

FRONT AXLE

On-vehicle Service (Cont'd)

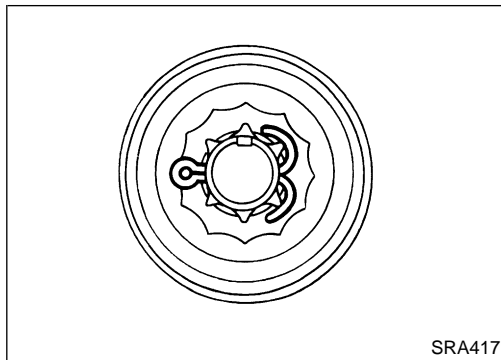

9. Spread cotter pin.
10. Install hub cap.

Preload Adjustment (4WD models)

NGAX0006S02

Adjust wheel bearing preload after wheel bearing has been replaced or front axle has been reassembled.

Adjust wheel bearing preload as follows:

1. Before adjustment, thoroughly clean all parts to prevent dirt entry.

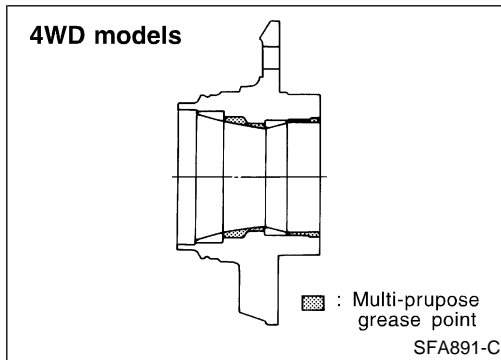

2. Apply multi-purpose grease sparingly to the following parts:
 - Threaded portion of spindle
 - Contact surface between wheel bearing washer and outer wheel bearing
 - Grease seal lip
 - Wheel hub (as shown at left) **18 - 23 g (0.63 - 0.81 oz)**

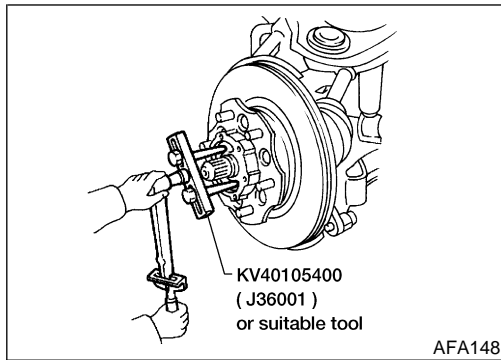

3. Tighten wheel bearing lock nut with Tool.
☞ : **78 - 98 N-m (8 - 10 kg-m, 58 - 72 ft-lb)**
4. Turn wheel hub several times in both directions.
5. Loosen wheel bearing lock nut so that torque becomes 0 N·m (0 kg-m, 0 ft-lb).
6. Retighten wheel bearing lock nut with Tool.
☞ : **0.5 - 1.5 N-m (0.05 - 0.15 kg-m, 4.3 - 13.0 in-lb)**

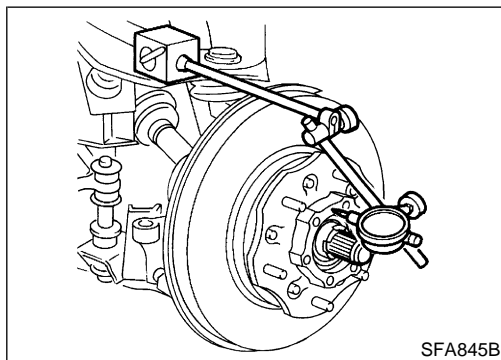

7. Turn wheel hub several times in both directions.
8. Retighten wheel bearing lock nut with Tool.
☞ : **0.5 - 1.5 N-m (0.05 - 0.15 kg-m, 4.3 - 13.0 in-lb)**
9. Measure wheel bearing axial end play.
Axial end play: 0 mm (0 in)

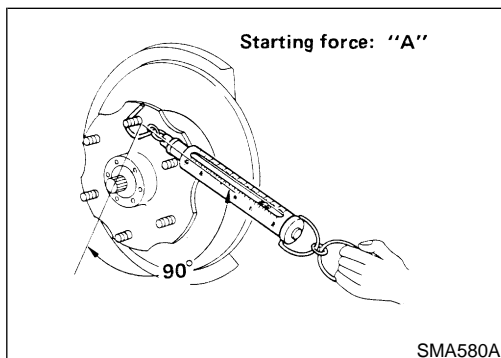

10. Measure starting force "A" at wheel hub bolt.

FRONT AXLE

On-vehicle Service (Cont'd)

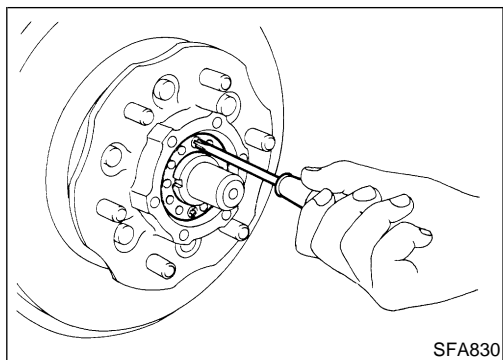

11. Install lock washer by tightening the lock nut within 15 to 30 degrees to align screw holes.
12. Turn wheel hub several times in both directions to seat wheel bearing correctly.
13. Measure starting force "B" at wheel hub bolt. Refer to step 10.
14. Wheel bearing preload "C" can be calculated as shown below.

$$C = B - A$$

Wheel bearing preload "C":

7.06 - 20.99 N (0.72 - 2.14 kg, 1.59 - 4.72 lb)

15. If wheel bearing preload "C" is outside specifications, remove lock washer. Tighten or loosen lock nut within ± 15 degrees (Refer to step 11 above). Install lock washer, then repeat steps 12, 13 and 14.
16. Repeat above procedures until correct axial end play and wheel bearing preload are obtained.
17. Tighten screws.
18. Install free-running hub.
19. Tighten bolts.

 : **1.2 - 1.8 N-m (0.12 - 0.18 kg-m, 10.4 - 15.6 in-lb)**

 : **25 - 34 N-m (2.5 - 3.5 kg-m, 18 - 25 ft-lb)**

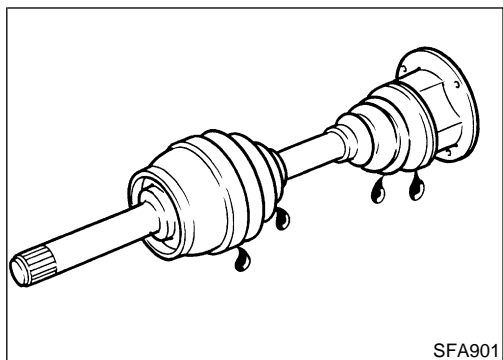

DRIVE SHAFT

- Check for grease leakage and damage.

CAUTION:

- The ZF100 (wheel side) type joint assembly has two types of boot material; one is made of rubber and the other is made of plastic.
- Do not disassemble the joint assembly with the plastic boot. If the boot or joint is damaged, replace the drive shaft assembly.

GI

MA

EM

LC

EC

FE

CL

MT

AT

TF

PD

AX

SU

BR

ST

RS

BT

HA

SC

EL

IDX

FRONT AXLE

Components

NGAX0008

Components

2WD models
SEC.400

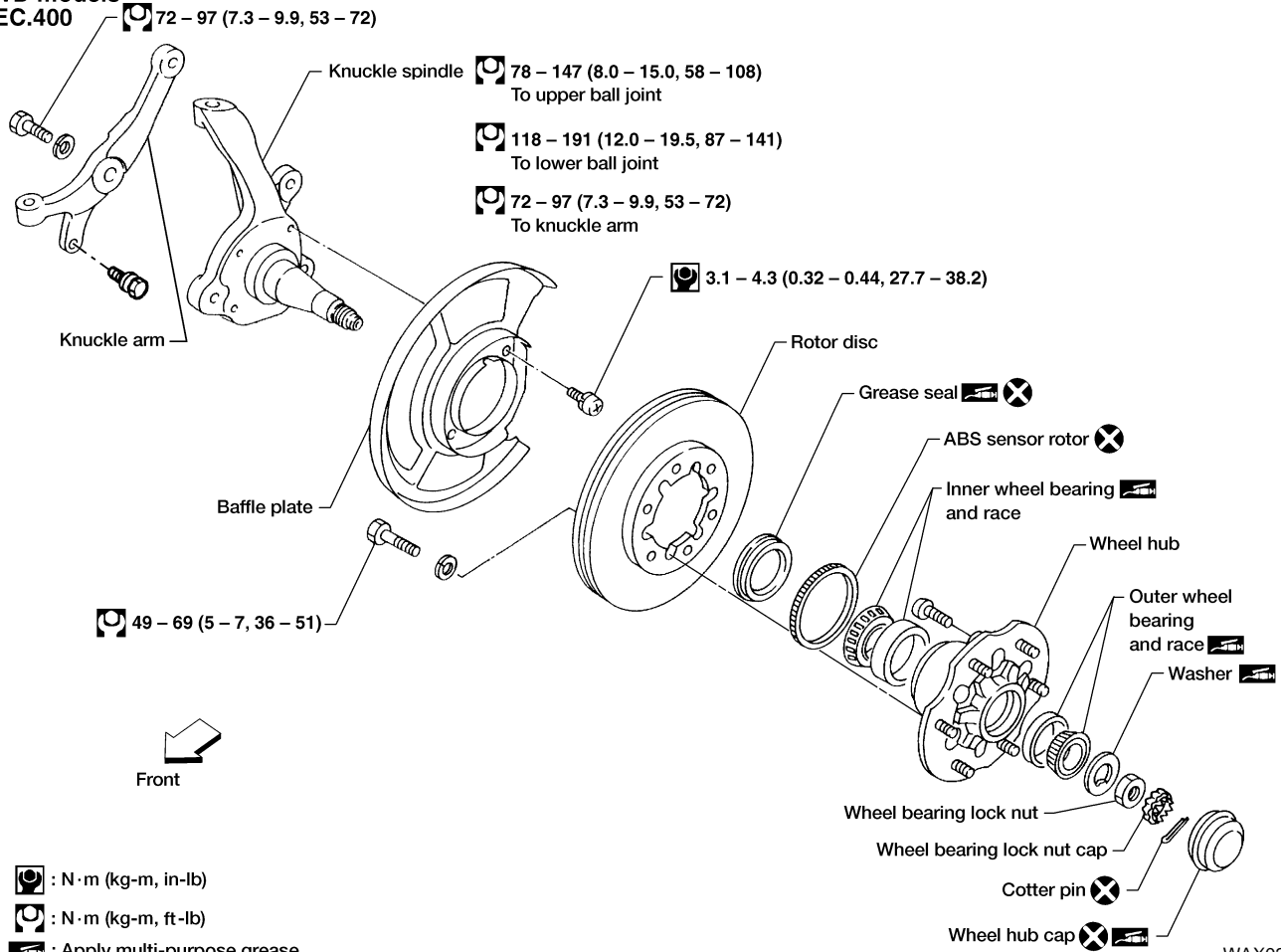

WAX029

FRONT AXLE

Components (Cont'd)

4WD models
SEC. 391 • 400

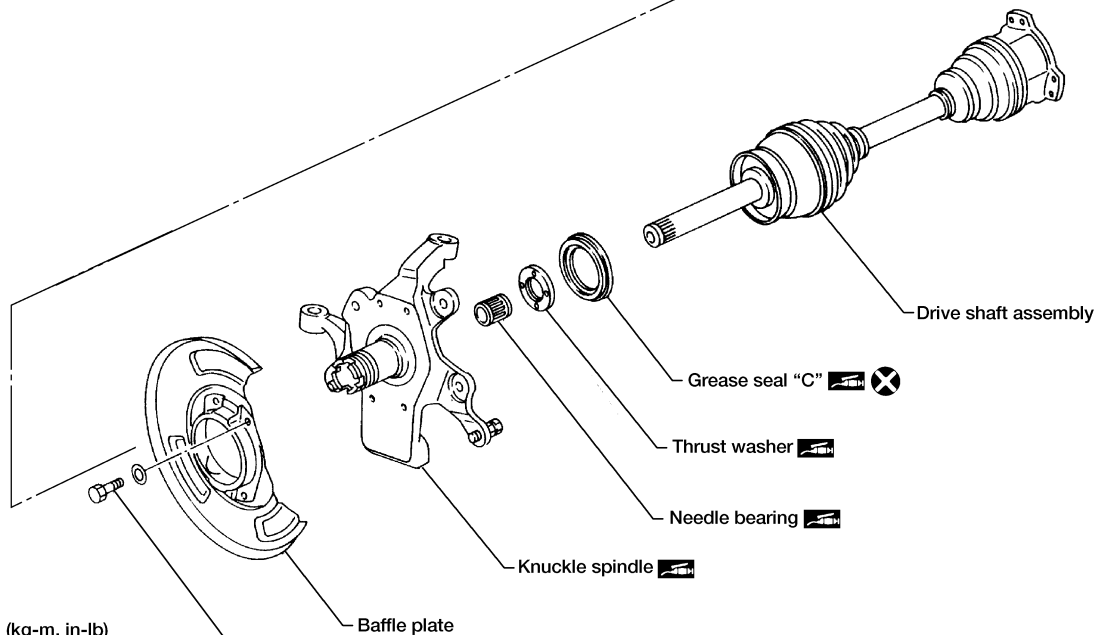
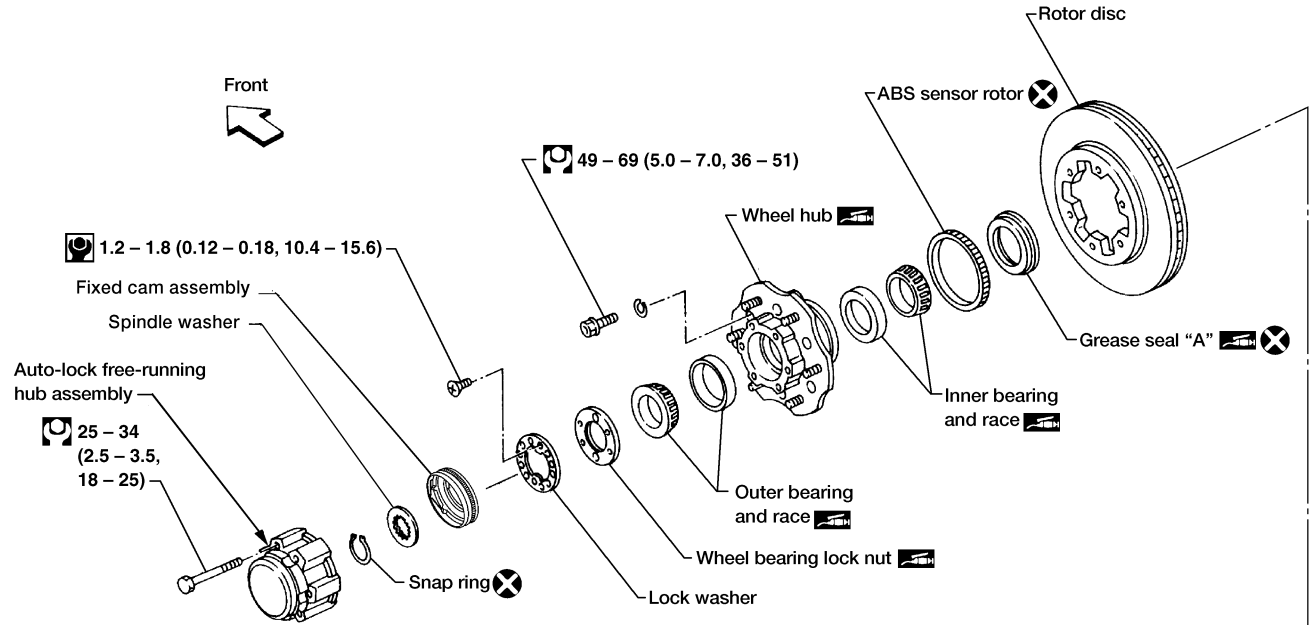

- : N·m (kg-m, in-lb)
- : N·m (kg-m, ft-lb)
- : Apply multi-purpose grease
- 3.2 - 4.3 (0.32 - 0.44, 28 - 38)

GI
MA
EM
LC
EC
FE
CL
MT
AT
TF
PD
AX
SU
BR
ST
RS
BT
HA
SC
EL
IDX

WAX026

FRONT AXLE

Manual-lock Free-running Hub

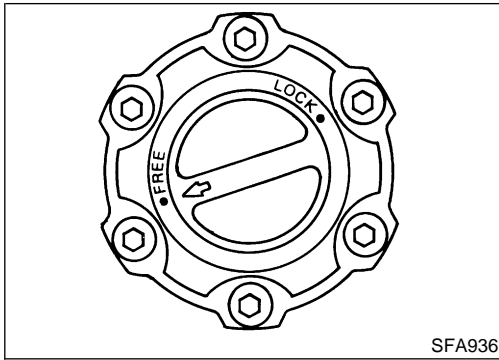

Manual-lock Free-running Hub DESCRIPTION

NGAX0041

Manual-lock free-running hubs are locked by rotating the operation knob to the LOCK position. The drive shaft and hub are now locked. If the teeth are not meshed, the operation is possible and the connection can be made simultaneously with the rotation of the hub. When the operation knob is rotated to the FREE position, the lock between the drive shaft and the hub is released.

In most cases, the “ratcheting” noise sometimes heard in manual-lock free-running hubs occurs when one hub is locked and the opposite hub is unlocked. The noise is heard in the side opposite to the locked hub. For example, if the noise is heard at the left front wheel, the **right** front hub is still locked and is not unlocking. This condition may be caused by a mechanical condition in one of the hubs or by incorrect operation on the part of the vehicle driver.

The ratcheting noise does not necessarily cause damage to the good hub. If the noise is caused by incorrect operation, counsel the driver of the vehicle. If replacement is necessary, replace only the defective parts. It is not necessary to replace manual-lock free-running hubs in pairs.

REMOVAL AND INSTALLATION

NGAX0042

SEC. 400

*: Lubricating parts

When installing manual-lock free-running hub, use multi-purpose grease.

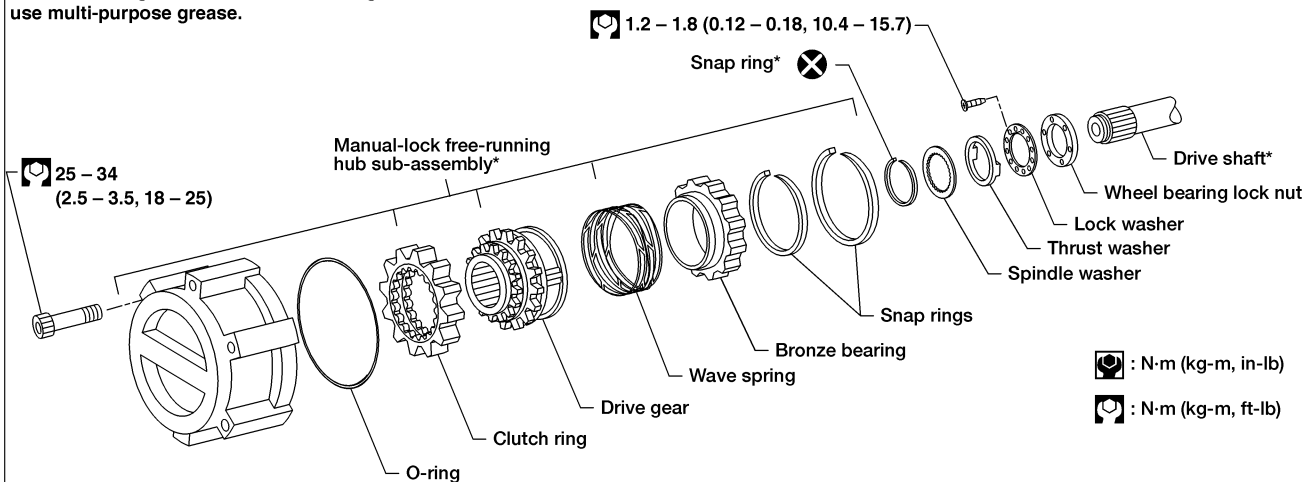

AAAX007

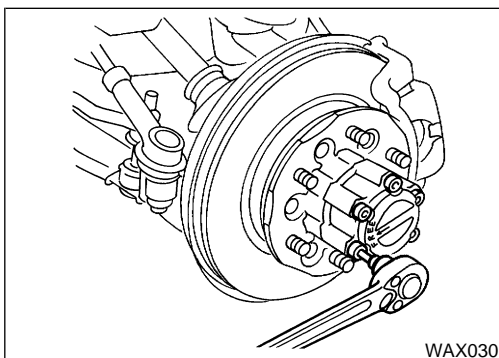

1. Set knob of manual-lock free-running hub in the FREE position.
2. Remove manual-lock free-running hub.

FRONT AXLE

Manual-lock Free-running Hub (Cont'd)

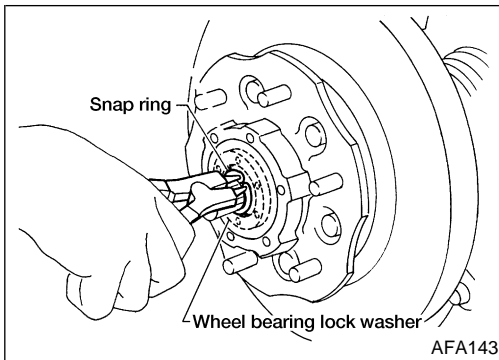

3. Remove snap ring.
4. Remove spindle washer and thrust washer.
5. When installing manual-lock free-running hub, make sure the hub is in the FREE position.
6. Place the thrust washer, spindle washer and then the snap ring over the axle shaft and position them between the two locking grooves.
7. While supporting the axle shaft behind the knuckle, use an appropriate sized deep socket to securely seat the snap ring into the inner locking groove.

CAUTION:

Visually verify that the snap ring is fully seated into the locking groove.

8. After installing manual-lock free-running hub, check operation.

During installation, apply recommended grease to the parts shown in the above illustration.

INSPECTION

1. Check axle axial end play. Refer to "INSTALLATION", AX-23.^{NGAX0043}
2. Inspect thrust washer assembly. If this part shows evidence of galling or heat damage—usually caused by too little axle axial end play—replace as necessary. Check axle axial end play if this part is replaced. Refer to "INSTALLATION", AX-23.
3. Inspect hub assembly. Hold inner splines on a finger and spin the outer body. If the hub shows signs of damage, or if there is excessive metallic clicking when the hub is spun, replace with a new one.
4. Check that the knob moves smoothly and freely.
5. Check that the clutch moves smoothly in the body.

NOTE:

New hubs are greased during manufacture. No additional grease is required.

CAUTION:

Any hub, the original or a new one, should go onto the axle freely by hand and fit flush against its seat. If it does not fit flush, do not pull the hub into place by tightening the bolts. The hub is possibly misaligned inside and tightening the bolts will cause damage. Remove the hub and turn to align correctly before continuing.

6. Once repair is complete, test drive to check for correct operation and the absence of noise.

Auto-lock Free-running Hub

DESCRIPTION

Auto-lock free-running hubs are locked by placing the transfer case into the 4WD mode and moving the vehicle. They are unlocked by placing the transfer case into 2WD mode and moving the vehicle in reverse gear in a straight line for at least 2–3 meters (7–10 feet).

In most cases, the "ratcheting" noise sometimes heard in auto-lock free-running hubs occurs when one hub is locked and the opposite hub is unlocked. The noise is heard in the side opposite to the locked hub. For example, if the noise is heard at the left front wheel,

GI
MA
EM
LC
EC
FE
CL
MT
AT
TF
PD
AX
SU
BR
ST
RS
BT
HA
SC
EL
IDX

FRONT AXLE

Auto-lock Free-running Hub (Cont'd)

the **right** front hub is still locked and is not unlocking. This condition may be caused by a mechanical condition in one of the hubs or by incorrect operation on the part of the vehicle driver, for example by not backing up in a straight line to unlock the hubs, by not backing up enough, or by shifting into 4WD at too high a vehicle speed, etc.

The ratcheting noise does not necessarily cause damage to the good hub. If the noise is caused by incorrect operation, counsel the driver of the vehicle. If replacement is necessary, replace only the defective parts. It is not necessary to replace auto-lock free-running hubs in pairs.

Use the trouble diagnosis chart to isolate the cause of the noise. Refer to "TROUBLE DIAGNOSIS FOR NOISE", AX-13.

REMOVAL AND INSTALLATION

NGAX0011

SEC. 400

* : Lubricating parts

When installing auto-lock free-running hub, use NISSAN GENUINE GREASE (KRC 19-00025) or equivalent grease.

Auto-lock free-running hub assembly

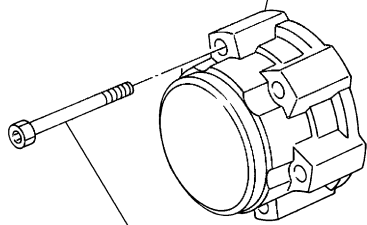

25 - 34 (2.5 - 3.5, 18 - 25)

Screw
1.2 - 1.8
(0.12 - 0.18, 10.4 - 15.6)

*Drive shaft

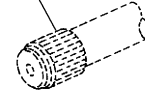

Wheel bearing lock nut

Lock washer

Fixed cam assembly

*Spindle washer

*Snap ring

: N·m (kg-m, in-lb)

: N·m (kg-m, ft-lb)

AAX008

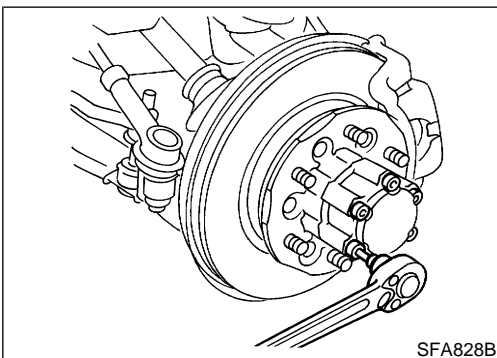

SFA828B

1. Remove auto-lock free-running hub assembly.

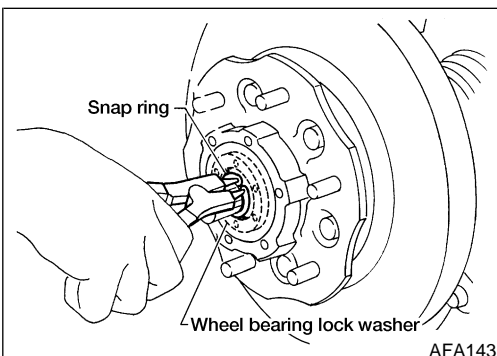

AFA143

2. Remove snap ring.
3. Remove spindle washer and fixed cam assembly.
4. Install fixed cam assembly.
Be sure to align the tabs of the fixed cam assembly to the notches of the knuckle.
5. Place the spindle washer and then the snap ring over the axle shaft and position them between the 2 locking grooves.
6. While supporting the axle shaft behind the knuckle, use an appropriate sized deep socket to securely seat the snap ring into the inner locking groove.

FRONT AXLE

Auto-lock Free-running Hub (Cont'd)

CAUTION:

Visually verify that the snap ring is fully seated into the locking groove.

7. After installing auto-lock free-running hub, check operation.

During installation, apply recommended grease to the parts shown in the above illustration.

INSPECTION

1. Check axle axial end play. Refer to "INSTALLATION", AX-23.
2. Inspect fixed cam (thrust washer) assembly. If this part shows evidence of galling or heat damage—usually caused by too little axle axial end play—replace as necessary. Check axle axial end play if this part is replaced. Refer to "INSTALLATION", AX-23.
3. Inspect hub assembly. Hold inner splines on a finger and spin the outer body. If the hub shows signs of damage, or if there is excessive metallic clicking when the hub is spun, replace with a new one.

NOTE:

New hubs are greased during manufacture. No additional grease is required.

New hubs are supplied with fixed cam assemblies.

CAUTION:

Any hub, the original or a new one, should go onto the axle freely by hand and fit flush against its seat. If it does not fit flush, do not pull the hub into place by tightening the bolts. The hub is possibly misaligned inside and tightening the bolts will cause damage. Remove the hub and turn to align correctly before continuing.

4. Once repair is complete, test drive to check for correct operation and the absence of noise.

TROUBLE DIAGNOSIS FOR NOISE

NGAX0040

Symptom	Possible cause	Repair order
Ratchet noise in hub after shifting the transfer case into 4WD at speeds higher than 40 km/h (25 mph).	1. Shifting into 4WD at higher speeds is difficult and may cause damage to transfer case	1. Stop the vehicle or decrease speed to less than 40 km/h (25 mph). Return the transfer case lever to the 2H position once, then re-shift to the 4H position. Move forward until the hubs lock.
Ratchet noise in hub after shifting or attempting to shift the transfer case into 4WD at speeds less than 40 km/h (25 mph).	1. Transfer case was not fully engaged or shifting was stopped halfway so that only one hub locked	1. Make sure the 4WD lamp on the dash is "ON" when shifting into 4WD. Slow or stop the vehicle. Shift into 2H, then back to 4H. Move forward until the hubs lock.
Ratchet noise in hub after shifting the transfer case into 4WD on snowy or muddy roads or on slopes.	1. If the rear wheels slip during the hub locking operation, noise can occur in the hubs	1. Reduce engine speed and drive forward slowly. The hubs will lock evenly and the noise will stop.
Ratchet noise in hub after shifting the transfer case into 2WD and backing up to unlock the hubs.	1. The hubs may not be fully released	1. Stop the vehicle, make sure the transfer case lever is fully in the 2H position, then back up slowly in a straight line at least 2-3 meters (7-10 feet).

FRONT AXLE

Auto-lock Free-running Hub (Cont'd)

Symptom	Possible cause	Repair order
Ratchet noise in hub when driving in extremely cold weather.	1. The viscosity of differential oil grows higher in extreme cold, increasing the possibility that one hub may lock. A lower viscosity differential fluid may be required for extreme cold temperatures. See owner's manual	1. Shift the transfer case into 4H and drive the vehicle for 10 minutes or more to warm the differential oil. Then shift to 2WD and back up in a straight line for at least 2-3 meters (7-10 feet) to disengage the hubs.
Continual ratchet noise in one wheel when moving forward.	1. A hub may be mechanically locked either by damage or misinstallation	1. Remove hubs and inspect. Refer to "INSPECTION", AX-13. Pay special attention to the hub opposite the noisy side. The ratcheting does not necessarily cause damage to the good hub.

Wheel Hub and Rotor Disc REMOVAL AND INSTALLATION

NGAX0012

CAUTION:

If equipped with ABS, disconnect the ABS wheel sensor from the assembly before removing the front axle assembly. Then move it away from the front axle assembly area. Failure to do so may result in damage to the sensor wires and the sensor becoming inoperative.

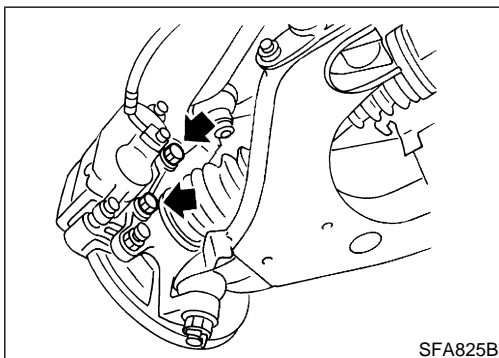

1. Remove free-running hub assembly (4WD models). Refer to "REMOVAL AND INSTALLATION", AX-12.
2. Remove brake caliper assembly without disconnecting hydraulic line.

Brake hose need not be disconnected from brake caliper. In this case, suspend caliper assembly with wire so as not to stretch brake hose.

Be careful not to depress brake pedal, or piston will pop out. Make sure brake hose is not twisted.

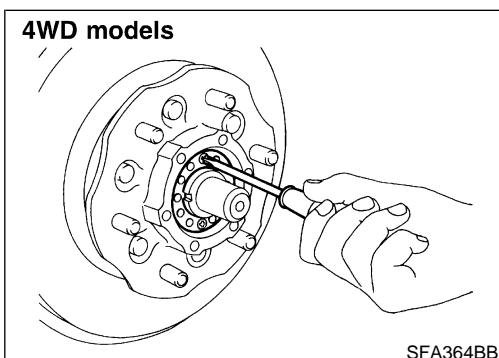

3. Remove lock washer (4WD models).

FRONT AXLE

Wheel Hub and Rotor Disc (Cont'd)

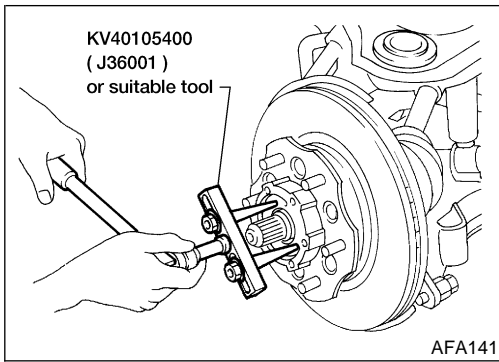

- Remove wheel bearing lock nut.
2WD Models: With suitable tool
4WD Models: With Tool

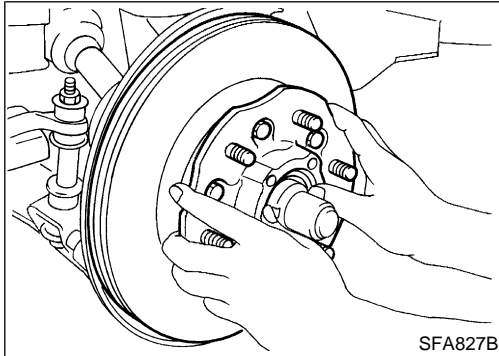

- Remove wheel hub and wheel bearing.

Be careful not to drop outer bearing.

- After installing wheel hub and wheel bearing, adjust wheel bearing preload.
Refer to "Preload Adjustment (2WD models)", AX-5; or "Preload Adjustment (4WD models)", AX-6.

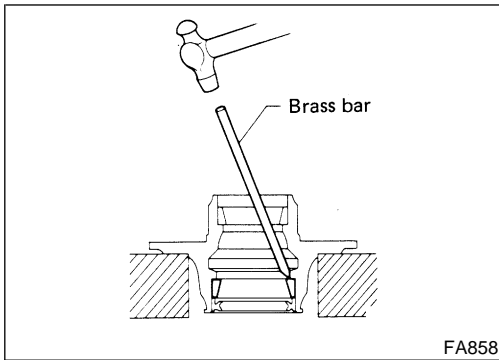

DISASSEMBLY

- Remove grease seal and bearing outer races with suitable ^{NGAX0013} brass bar. AT

INSPECTION

Thoroughly clean wheel bearings and wheel hub. ^{NGAX0014}

Wheel Bearings

- Make sure wheel bearings roll freely and are free from noise, cracks, pitting and wear. ^{NGAX0014S01} BR

Wheel Hub

- Check wheel hub for cracks by using a magnetic exploration or dyeing test. ^{NGAX0014S02} ST

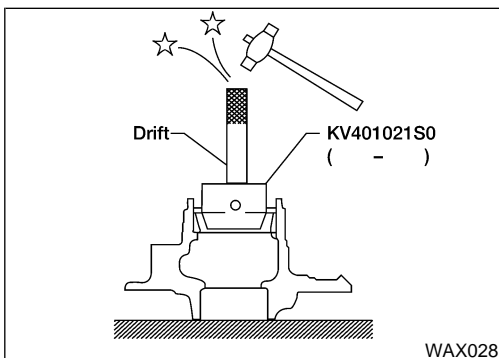

ASSEMBLY

- Install bearing outer race with Tool until it is fully seated in hub. ^{NGAX0015}

GI

MA

EM

LC

EC

FE

CL

MT

AT

TF

PD

AX

SU

BR

ST

RS

BT

HA

SC

EL

IDX

FRONT AXLE

Wheel Hub and Rotor Disc (Cont'd)

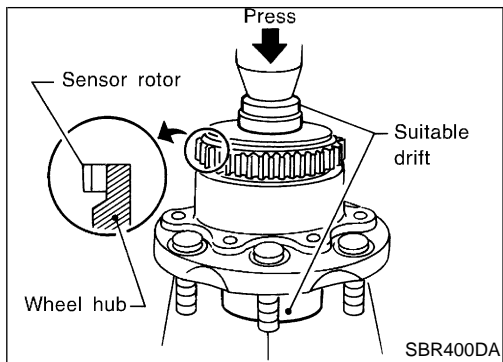

2. Install the sensor rotor using suitable drift and press. Always replace sensor rotor with new one. Pay attention to the direction of front sensor rotor as shown in figure.

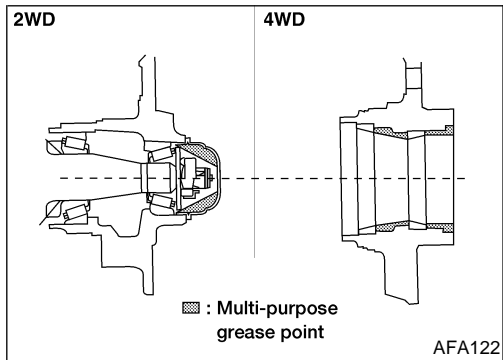

3. Pack multi-purpose grease in wheel hub and hub cap (2WD models).

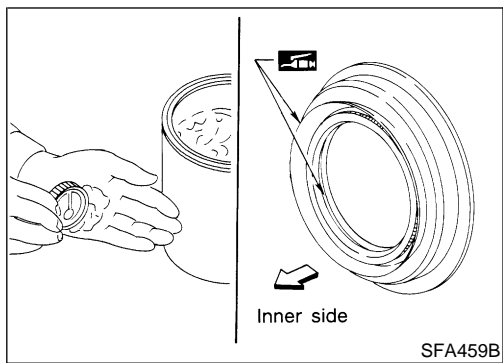

4. Apply multi-purpose grease to each bearing cone.
5. Pack grease seal lip with multi-purpose grease, then install it into wheel hub with suitable drift.

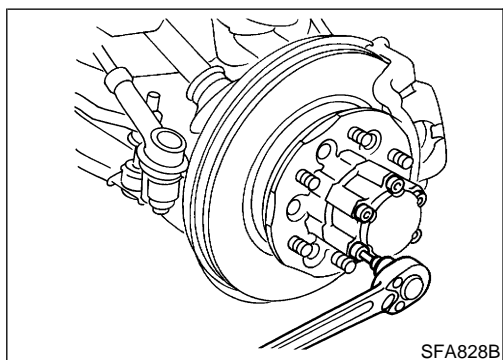

Knuckle Spindle REMOVAL

NGAX0016

1. Remove free-running hub assembly (4WD models). Refer to "REMOVAL AND INSTALLATION", AX-12.
2. Remove wheel hub and rotor disc. Refer to "REMOVAL AND INSTALLATION", AX-14.

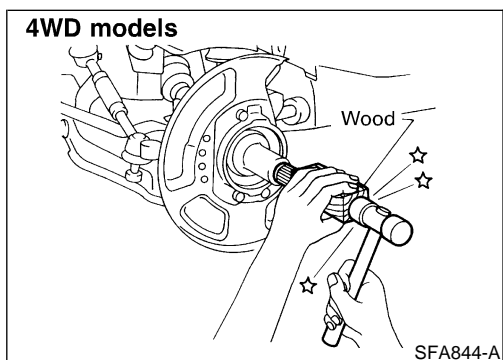

3. Separate drive shaft from knuckle spindle by slightly tapping drive shaft end (4WD models).

FRONT AXLE

Knuckle Spindle (Cont'd)

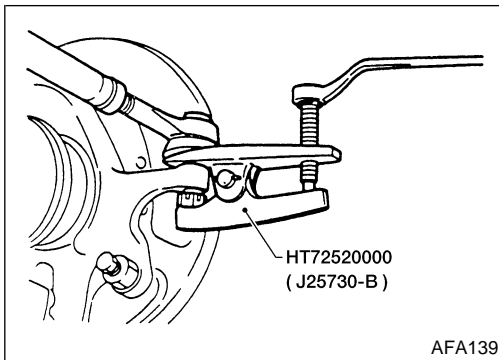

4. Separate tie-rod from knuckle spindle with Tool.
Install stud nut conversely on stud bolt so as not to damage stud bolt.

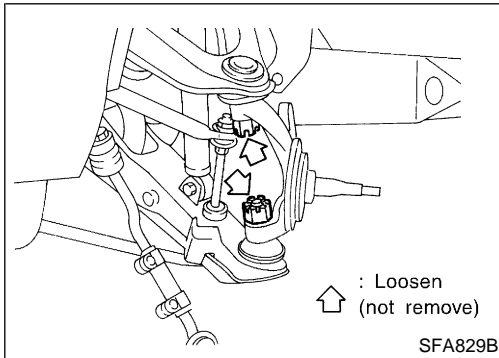

5. Separate knuckle spindle from ball joints.
a. Loosen (do not remove) upper and lower ball joint tightening nuts.

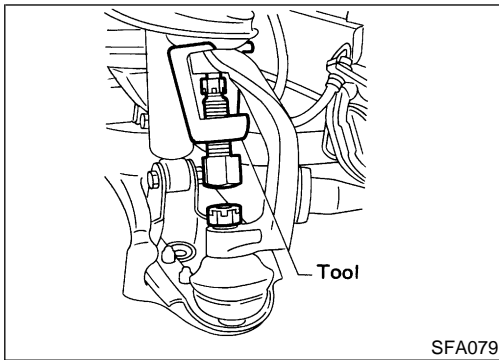

- b. Separate knuckle spindle from upper and lower ball joint studs with Tool.
During above operation, never remove ball joint nuts which are loosened in step (a) above.

Tool:

2WD Models

ST29020001 (J24319-01)

4WD Models

HT72520000 (J25730-B)

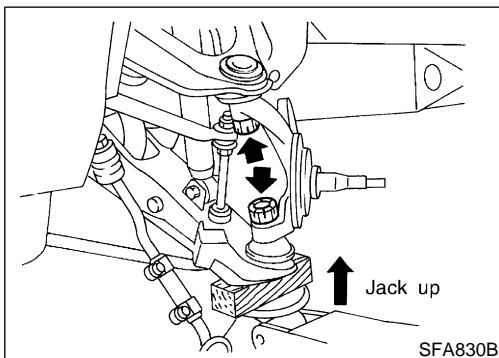

- c. Remove ball joint tightening nuts.
Support lower link with jack.
d. Remove knuckle spindle from upper and lower links.

INSPECTION

Knuckle Spindle

- Check knuckle spindle for deformation, cracks and other damage by using a magnetic exploration or dyeing test.

NGAX0017

NGAX0017S01

Bearing Spacer (2WD models)

- Check bearing spacer for damage.

NGAX0017S02

Needle Bearing (4WD models)

- Check needle bearing for wear, scratches, pitting, flaking and burn marks.

NGAX0017S03

GI

MA

EM

LC

EC

FE

CL

MT

AT

TF

PD

AX

SU

BR

ST

RS

BT

HA

SC

EL

IDX

FRONT AXLE

Knuckle Spindle (Cont'd)

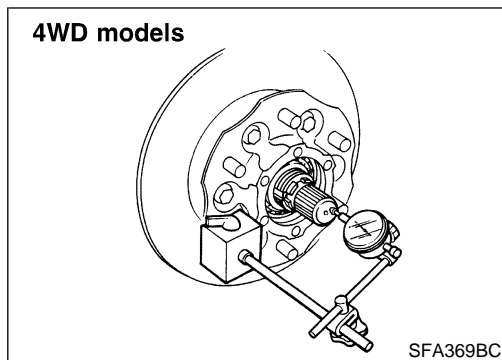
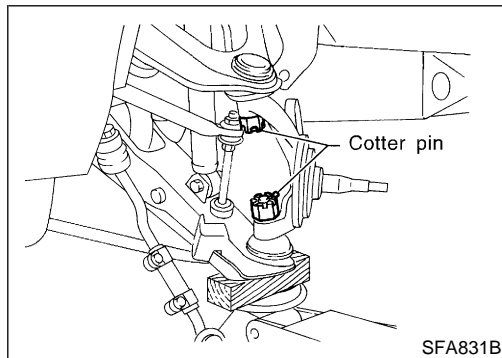
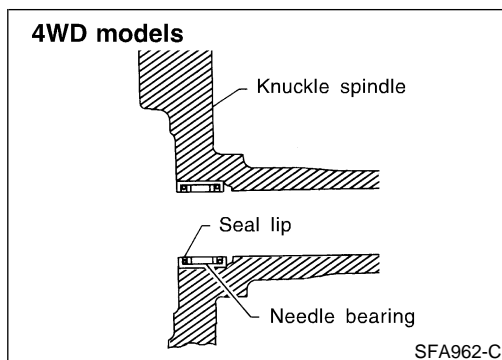

INSTALLATION

NGAX0018

1. Install needle bearing into knuckle spindle (4WD models).

Make sure that needle bearing is facing in the proper direction. Apply multi-purpose grease.

2. Install knuckle spindle to upper and lower ball joints with lower link jacked up.

CAUTION:

Make sure that oil and grease do not come into contact with tapered areas of ball joint, knuckle spindle and threads of ball joint.

3. Connect tie-rod to knuckle spindle.
4. Install wheel hub and rotor disc. Refer to "REMOVAL AND INSTALLATION", AX-14.

5. After installing knuckle spindle, adjust wheel bearing preload. Refer to "Preload Adjustment (2WD models)", AX-5; or "Preload Adjustment (4WD models)", AX-6.
6. After installing drive shaft, check drive shaft axial end play. **Do not reuse snap ring once it has been removed.** Refer to "INSTALLATION", AX-23.
7. Install free-running hub assembly (4WD models). Refer to "REMOVAL AND INSTALLATION", AX-12.

Drive Shaft

COMPONENTS

NGAX0019

CAUTION:

- The ZF100 (wheel side) type joint assembly has two types of boot material; one is made of rubber and the other is made of plastic.
- Do not disassemble the joint assembly with the plastic boot. If the boot or joint is damaged, replace the drive shaft assembly.

FRONT AXLE

Drive Shaft (Cont'd)

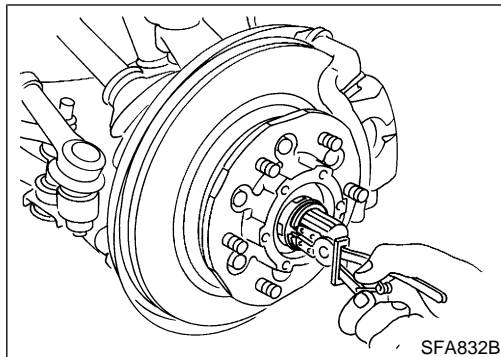
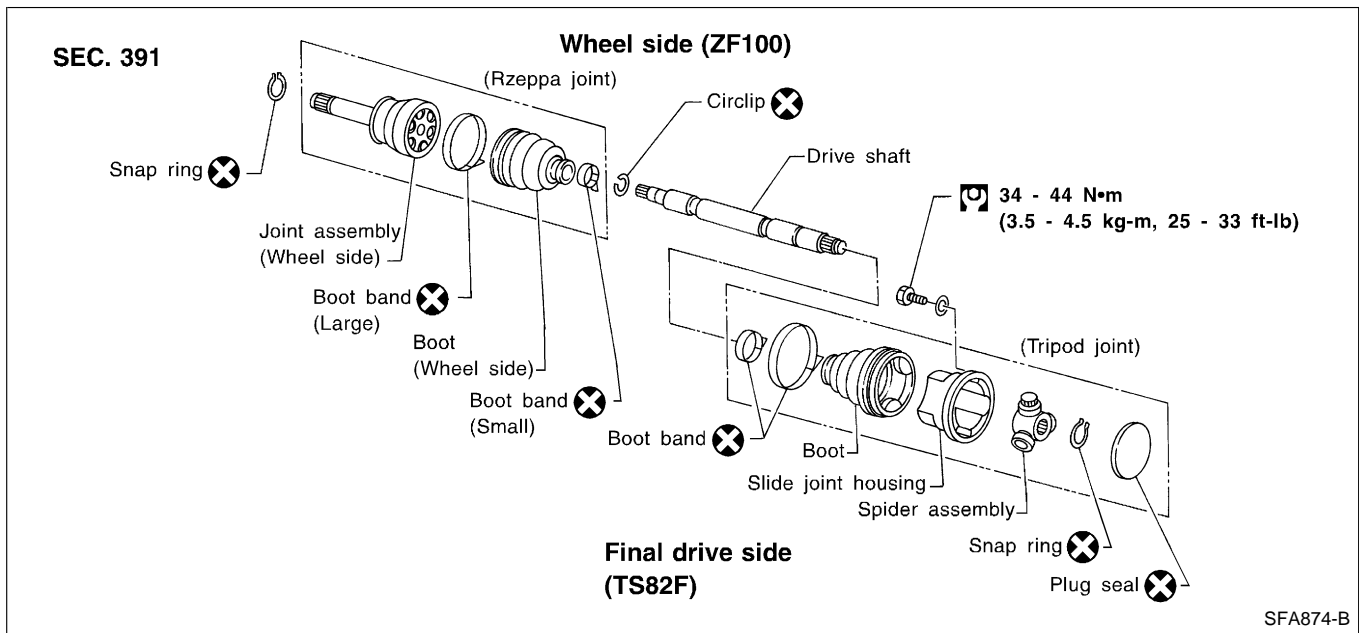

REMOVAL

1. Remove free-running hub or drive flange and snap ring. Refer to "REMOVAL AND INSTALLATION", AX-12.
2. Remove torsion bar spring. Refer to **SU-12**, "REMOVAL".
3. Remove shock absorber lower bolt.
4. Remove lower link bolts.

Support lower link with jack.

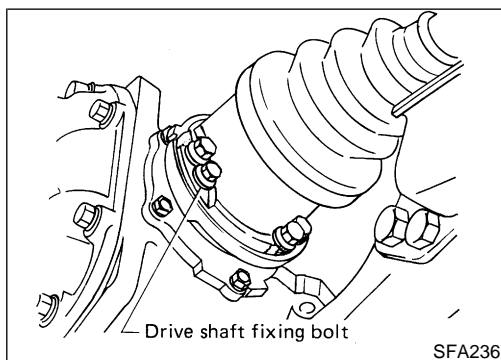

5. Remove drive shaft to final drive bolts.

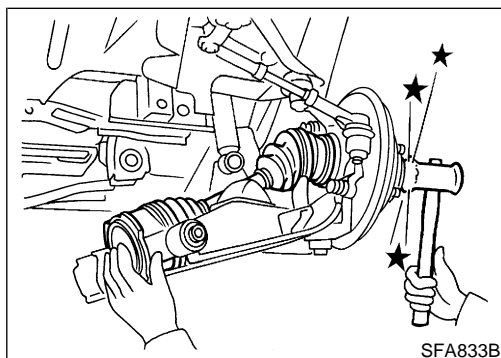

6. Separate drive shaft from knuckle spindle by slightly tapping end of drive shaft.

GI
MA
EM
LC
EC
FE
CL
MT
AT
TF
PD
AX
SU
BR
ST
RS
BT
HA
SC
EL
IDX

FRONT AXLE

Drive Shaft (Cont'd)

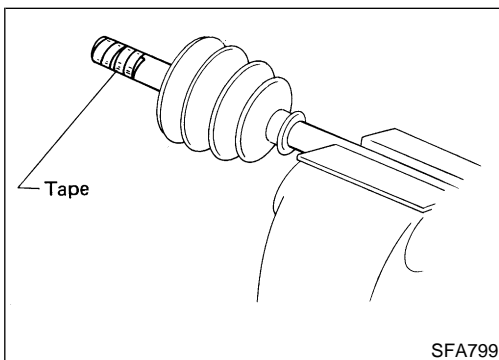
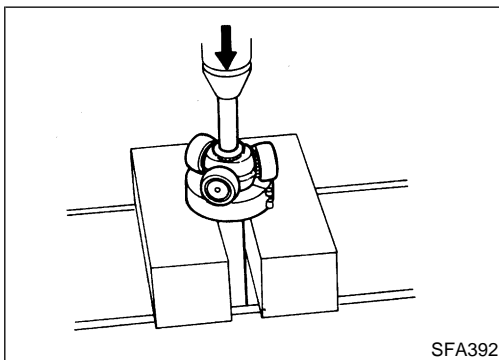
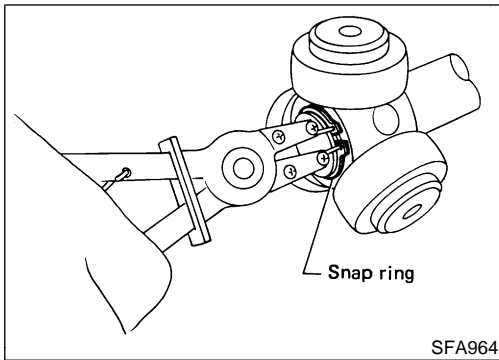
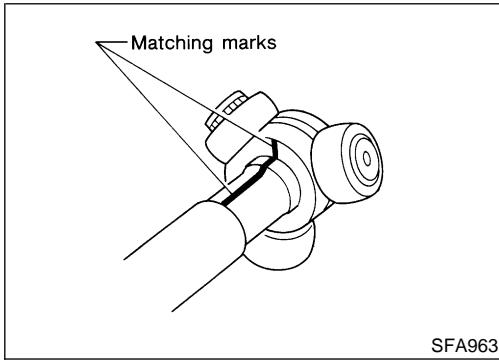
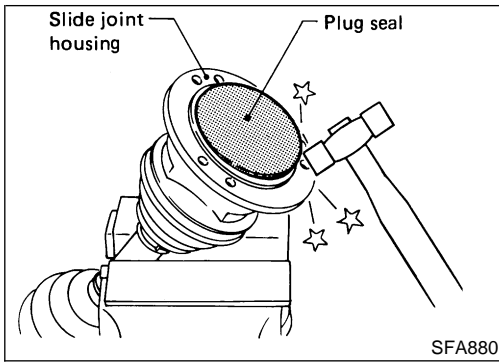

DISASSEMBLY

Final Drive Side (TS82F)

NGAX0021

NGAX0021S01

1. Remove plug seal from slide joint housing by lightly tapping around slide joint housing.
2. Remove boot bands.

3. Move boot and slide joint housing toward wheel side, and apply matching marks.

4. Remove snap ring.

5. Detach spider assembly with press.

6. Draw out boot.
Cover drive shaft serration with tape to prevent damaging the boot.

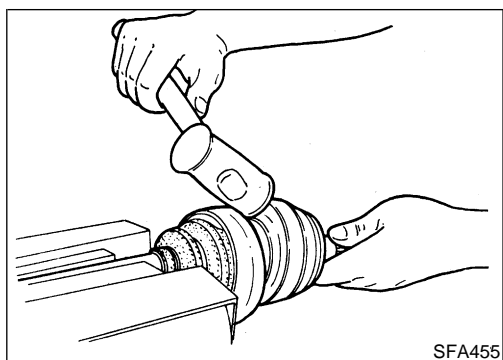

Wheel Side (ZF100)

NGAX0021S02

CAUTION:

- The ZF100 (wheel side) type joint assembly has two types of boot material; one is made of rubber and the other is made of plastic.
- Do not disassemble the joint assembly with the plastic boot. If the boot or joint is damaged, replace the drive shaft assembly.

The procedures for the joint with the rubber boot are as follows:

- Before separating joint assembly, put matching marks on drive shaft and joint assembly.
- Separate joint assembly with suitable tool.
- **Be careful not to damage threads on drive shaft.**
- Remove boot bands.

INSPECTION

NGAX0022

Thoroughly clean all parts in cleaning solvent, and dry with compressed air. Check parts for evidence of deformation and other damage.

Drive Shaft

NGAX0022S01

Replace drive shaft if it is twisted, cracked or bent.

Boot

NGAX0022S02

Check boot for fatigue, cracks and wear. Replace boot and boot bands with new.

Joint Assembly (Final drive side)

NGAX0022S03

- Replace any parts of double offset joint which show signs of scorching, rust, wear or excessive play.
- Check serration for deformation. Replace if necessary.
- Check slide joint housing for any damage. Replace if necessary.

Joint Assembly (Wheel side)

NGAX0022S04

CAUTION:

- The ZF100 (wheel side) type joint assembly has two types of boot material; one is made of rubber and the other is made of plastic.
- Do not disassemble the joint assembly with the plastic boot. If the boot or joint is damaged, replace the drive shaft assembly.

Replace joint assembly if it is deformed or damaged.

ASSEMBLY

NGAX0023

- After drive shaft has been assembled, ensure that it moves smoothly over its entire range without binding.
- Use Nissan Genuine Grease or equivalent after every overhaul.

GI

MA

EM

LC

EC

FE

CL

MT

AT

TF

PD

AX

SU

BR

ST

RS

BT

HA

SC

EL

IDX

FRONT AXLE

Drive Shaft (Cont'd)

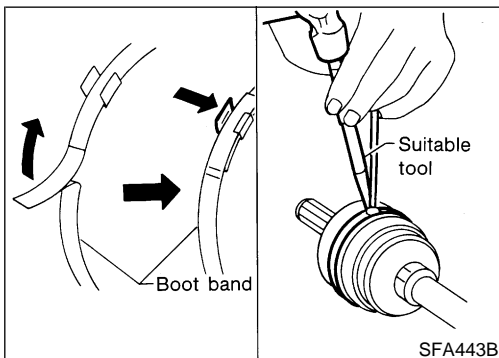
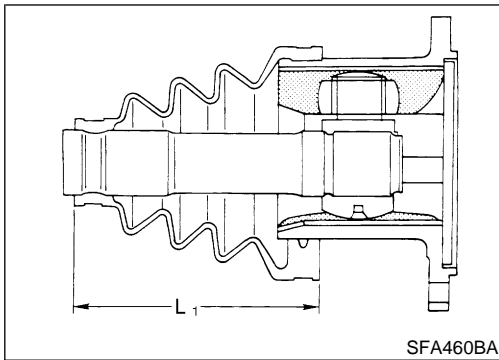
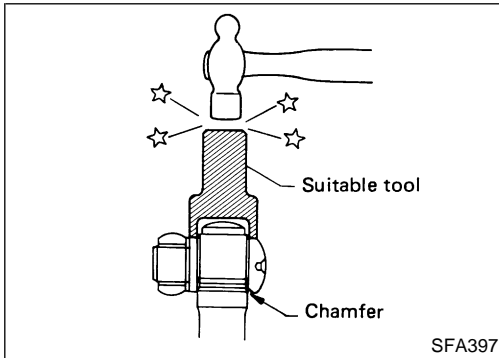
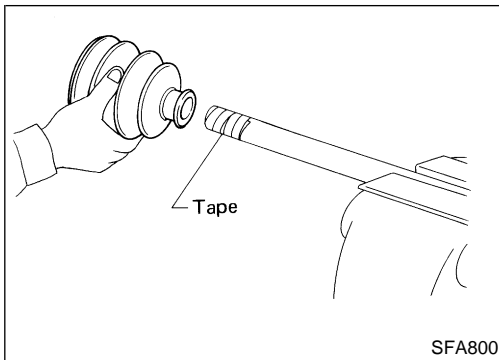

Final Drive Side (TS82F)

NGAX0023S01

1. Install new small boot band, boot and side joint housing to drive shaft.

Cover drive shaft serration with tape to prevent damaging boot during installation.

2. Install spider assembly securely, making sure marks are properly aligned.
 - **Press-fit with spider assembly serration chamfer facing shaft.**
3. Install new snap ring.

4. Pack with grease.

**Specified amount of grease:
95 - 105 g (3.35 - 3.70 oz)**

5. Make sure that the boot is properly installed on the drive shaft groove. Set the boot so that it does not swell or deform when its length is "L₁".

Length "L₁": 95 - 97 mm (3.74 - 3.82 in)

6. Lock new large boot band securely with a suitable tool, then lock new small boot band.

7. Install new plug seal to slide joint housing by lightly tapping it.

Apply suitable sealant to mating surface of plug seal.

Wheel Side (ZF100)

NGAX0023S02

CAUTION:

- The ZF100 (wheel side) type joint assembly has two types of boot material; one is made of rubber and the other is made of plastic.
- Do not disassemble the joint assembly with the plastic boot. If the boot or joint is damaged, replace the drive shaft assembly.

The procedures for the joint with the rubber boot are as follows:

FRONT AXLE

Drive Shaft (Cont'd)

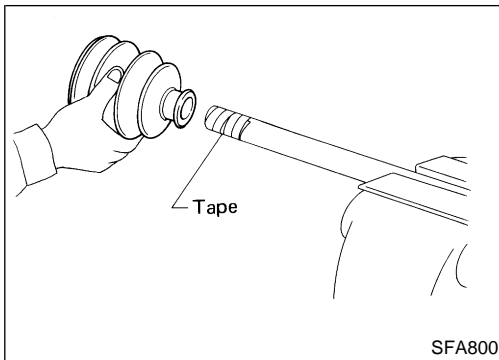

1. Install new small boot band and boot on drive shaft.
Cover drive shaft serration with tape to prevent damaging boot during installation.

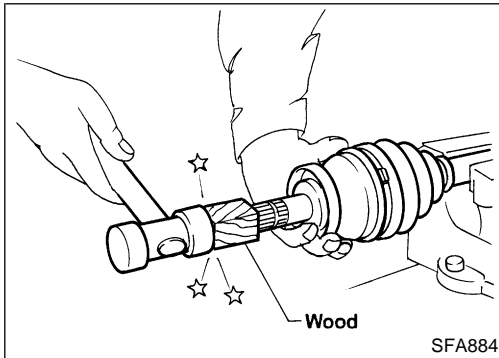

2. Set joint assembly onto drive shaft by lightly tapping it. Install joint assembly securely, ensuring that marks which were made during disassembly are properly aligned.

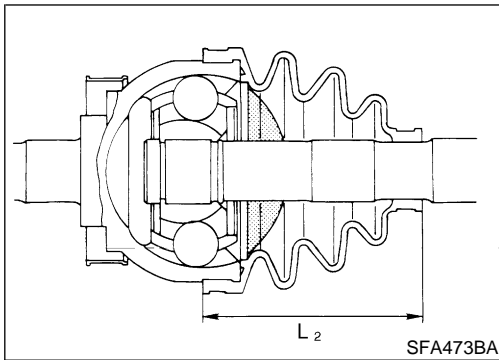

3. Pack drive shaft with specified amount of grease.
**Specified amount of grease:
115 - 125 g (4.06 - 4.41 oz)**
4. Make sure that the boot is properly installed on the drive shaft groove. Set the boot so that it does not swell or deform when its length is " L_2 ".
Length " L_2 ": 96 - 98 mm (3.78 - 3.86 in)

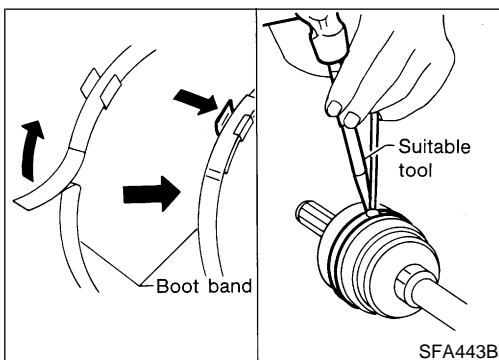

5. Lock new large boot band securely with a suitable tool, then lock new small boot band.

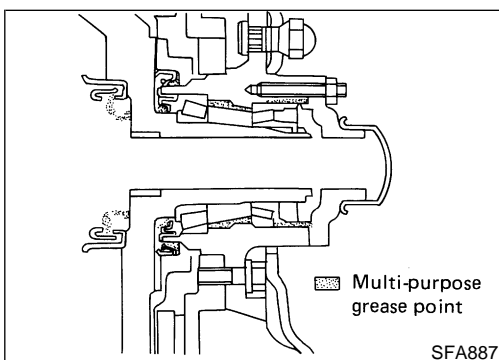

INSTALLATION

1. Apply multi-purpose grease.

NGAX0024

GI
MA
EM
LC
EC
FE
CL
MT
AT
TF
PD
AX
SU
BR
ST
RS
BT
HA
SC
EL
IDX

FRONT AXLE

Drive Shaft (Cont'd)

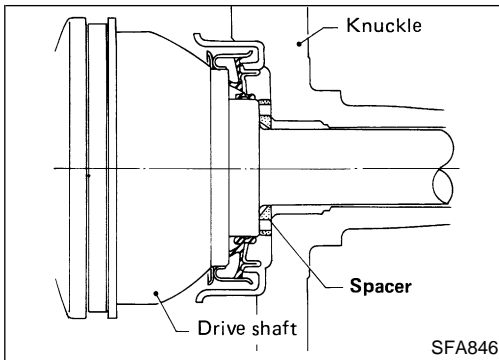

2. Install bearing spacer onto drive shaft.

Make sure that the bearing spacer is facing in the proper direction.

3. After installing wheel hub and wheel bearing, adjust wheel bearing preload. Refer to "Preload Adjustment (2WD models)", AX-5; or "Preload Adjustment (4WD models)", AX-6.

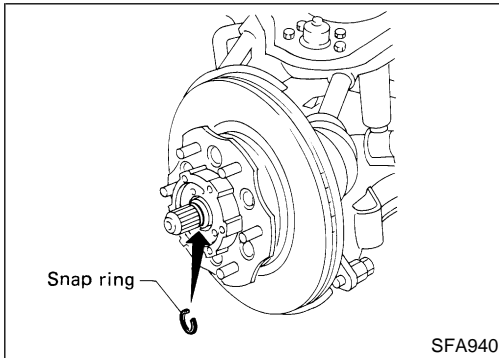

4. When installing drive shaft, adjust drive shaft axial end play by selecting a suitable snap ring.
 - a. Temporarily install new snap ring on drive shaft in the same thickness as the one that was removed.

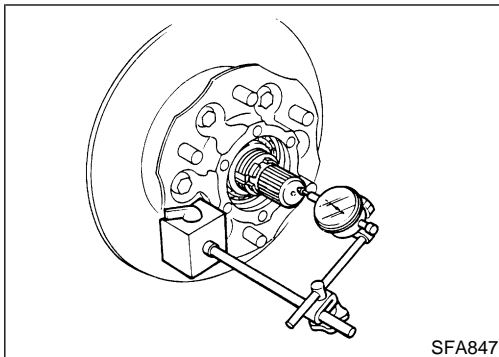

- b. Set dial gauge on drive shaft end.
- c. Measure axial end play of drive shaft.

Axial end play:

0.10 – 0.45 mm (0.004 – 0.0177 in)

- d. If axial end play is not within the specified limit, select another snap ring.

1.1 mm (0.043 in)	1.9 mm (0.075 in)
1.3 mm (0.051 in)	2.1 mm (0.083 in)
1.5 mm (0.059 in)	2.3 mm (0.091 in)
1.7 mm (0.067 in)	

FRONT AXLE

Service Data and Specifications (SDS)

Service Data and Specifications (SDS)

WHEEL BEARING (FRONT)

2WD Models

=NGAX0025

NGAX0025S01

Wheel bearing axial end play	mm (in)	0 (0)
Wheel bearing lock nut	Tightening torque	N·m(kg·m, ft·lb)
	Return angle	degree
Wheel bearing starting torque	At wheel hub bolt With new grease seal	N (kg, lb)
	With used grease seal	N (kg, lb)

4WD Models

NGAX0025S02

Wheel bearing lock nut	Tightening torque	N·m(kg·m, ft·lb)
	Retightening torque after loosening wheel bearing lock nut	N·m(kg·m, ft·lb)
	Axial end play	mm (in)
	Starting force at wheel hub bolt	N (kg, lb)
	Turning angle	degree
	Starting force at wheel hub bolt	N (kg, lb)
Wheel bearing preload at wheel hub bolt	N (kg, lb)	B - A

DRIVE SHAFT (4WD MODELS)

NGAX0026

Drive shaft joint type	Final drive side	TS82F
	Wheel side	ZF100*
	Fixed joint axial end play limit	mm (in)
Diameter	mm (in)	29.0 (1.142)
Grease	Quality	NISSAN genuine grease or equivalent
	Capacity	g (oz)
		Final drive side
Wheel side	115 - 125 (4.06 - 4.41)	
Boot length	mm (in)	
	Final drive side (L ₁)	95 - 97 (3.74 - 3.82)
Wheel side (L ₂)	96 - 98 (3.78 - 3.86)	

Final drive side

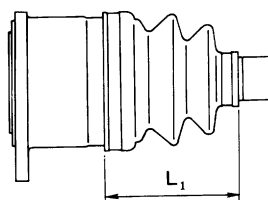

Wheel side

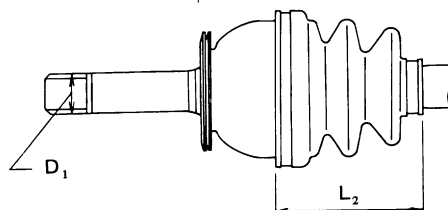

SFA877A

*: The ZF100 (wheel side) type joint assembly has two types of boot material; one is made of rubber and the other is made of plastic. Do not disassemble the joint assembly with the plastic boot. If the boot or joint is damaged, replace the drive shaft assembly.

FRONT AXLE

Service Data and Specifications (SDS) (Cont'd)

Drive Shaft Axial End Play

NGAX0026S01

Drive shaft axial end play mm (in)	0.10 – 0.45 (0.004 – 0.0177)
------------------------------------	------------------------------

Drive Shaft End Snap Ring

NGAX0026S02

Thickness mm (in)	Part No.*
1.1 (0.043)	39253-88G10
1.3 (0.051)	39253-88G11
1.5 (0.059)	39253-88G12
1.7 (0.067)	39253-88G13
1.9 (0.075)	39253-88G14
2.1 (0.083)	39253-88G15
2.3 (0.091)	39253-88G16

*: Always check with the Parts Department for the latest parts information.

REAR AXLE

Precautions

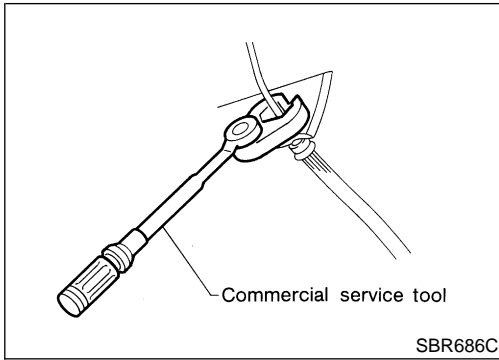

Precautions PRECAUTIONS

- When installing rubber parts, final tightening must be carried out under unladen condition* with tires on ground.
*: Fuel, radiator coolant and engine oil full. Spare tire, jack, hand tools and mats in designated positions.
- Use flare nut wrench when removing and installing brake tubes.
- After installing removed suspension parts, check wheel alignment and adjust if necessary.
- Always torque brake lines when installing.

NGAX0027

GI

MA

EM

LC

Preparation

SPECIAL SERVICE TOOLS

NGAX0028

The actual shapes of Kent-Moore tools may differ from those of special service tools illustrated here.

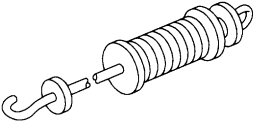
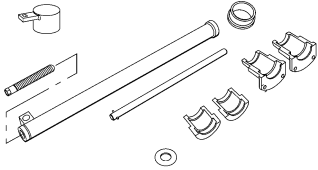
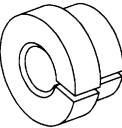
Tool number (Kent-Moore No.) Tool name	Description	
KV40101000 (J25604-01) Axle stand		Removing rear axle shaft
	NT159	
ST36230000 (J25840-A) Sliding hammer		Removing rear axle shaft
	NT126	
KV40106500 (J-45073) Rear axle shaft bearing puller		Removing wheel bearing, wheel bearing lock nut and ABS sensor rotor
	LPD022	
ST37840000 () Rear axle shaft guide		Installing rear axle shaft
	NT162	

FE

CL

MT

AT

TF

PD

AX

SU

BR

ST

RS

COMMERCIAL SERVICE TOOLS

NGAX0029

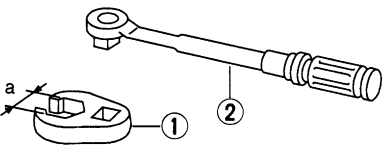
Tool name	Description	
1 Flare nut crowfoot 2 Torque wrench		Removing and installing each brake piping a: 10 mm (0.39 in)
	NT360	

BT

HA

SC

EL

IDX

REAR AXLE

Preparation (Cont'd)

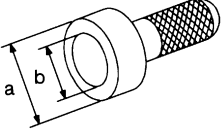
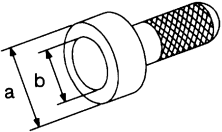
Tool name	Description
Bearing cage oil seal drift	 <p>Installing oil seal a: 74 mm (2.91 in) dia. b: 68 mm (2.68 in) dia.</p> <p>NT115</p>
Rear axle oil seal drift	 <p>Installing oil seal a: 54.5 mm (2.15 in.) b: 34.5 mm (1.36 in.)</p> <p>NT115</p>

REAR AXLE

Noise, Vibration and Harshness (NVH) Troubleshooting

Noise, Vibration and Harshness (NVH) Troubleshooting

Refer to "Noise, Vibration and Harshness (NVH) Troubleshooting", AX-4. =NGAX0030

GI

MA

EM

LC

On-vehicle Service

REAR AXLE PARTS

Check rear axle parts for excessive play, wear and damage. NGAX0031

- Shake each rear wheel to check for excessive play.

EC

FE

CL

MT

- Retighten all nuts and bolts to the specified torque.

 : Refer to **SU-21**, "Components".

AT

TF

PD

AX

SU

BR

ST

RS

BT

HA

SC

EL

IDX

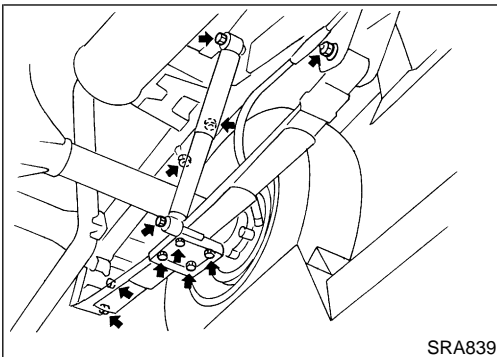
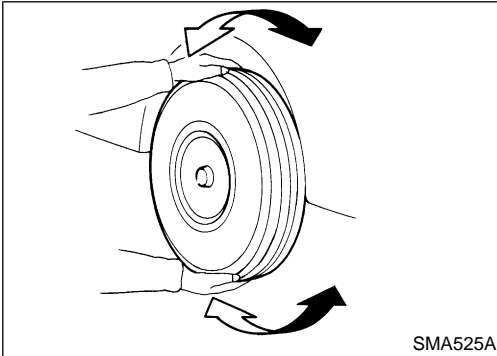

REAR AXLE

On-vehicle Service (Cont'd)

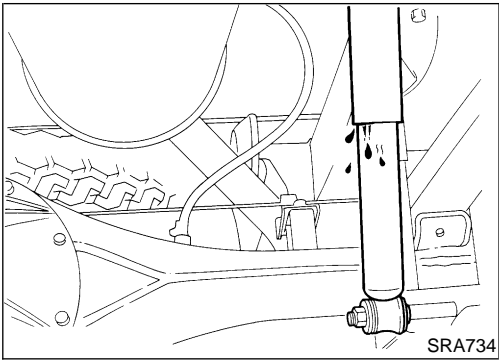

- Check shock absorber for oil leakage and other damage.
- Check shock absorber bushing for excessive wear and other damage.

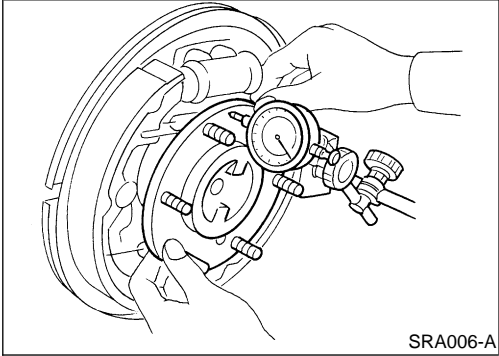

REAR WHEEL BEARING

NGAX0032

- Check that wheel bearings operate smoothly.
- Check axial end play.

Axial end play:

Refer to "WHEEL BEARING (REAR)", AX-38.

REAR AXLE

Components

Components

NGAX0033

SEC. 430
2WD models

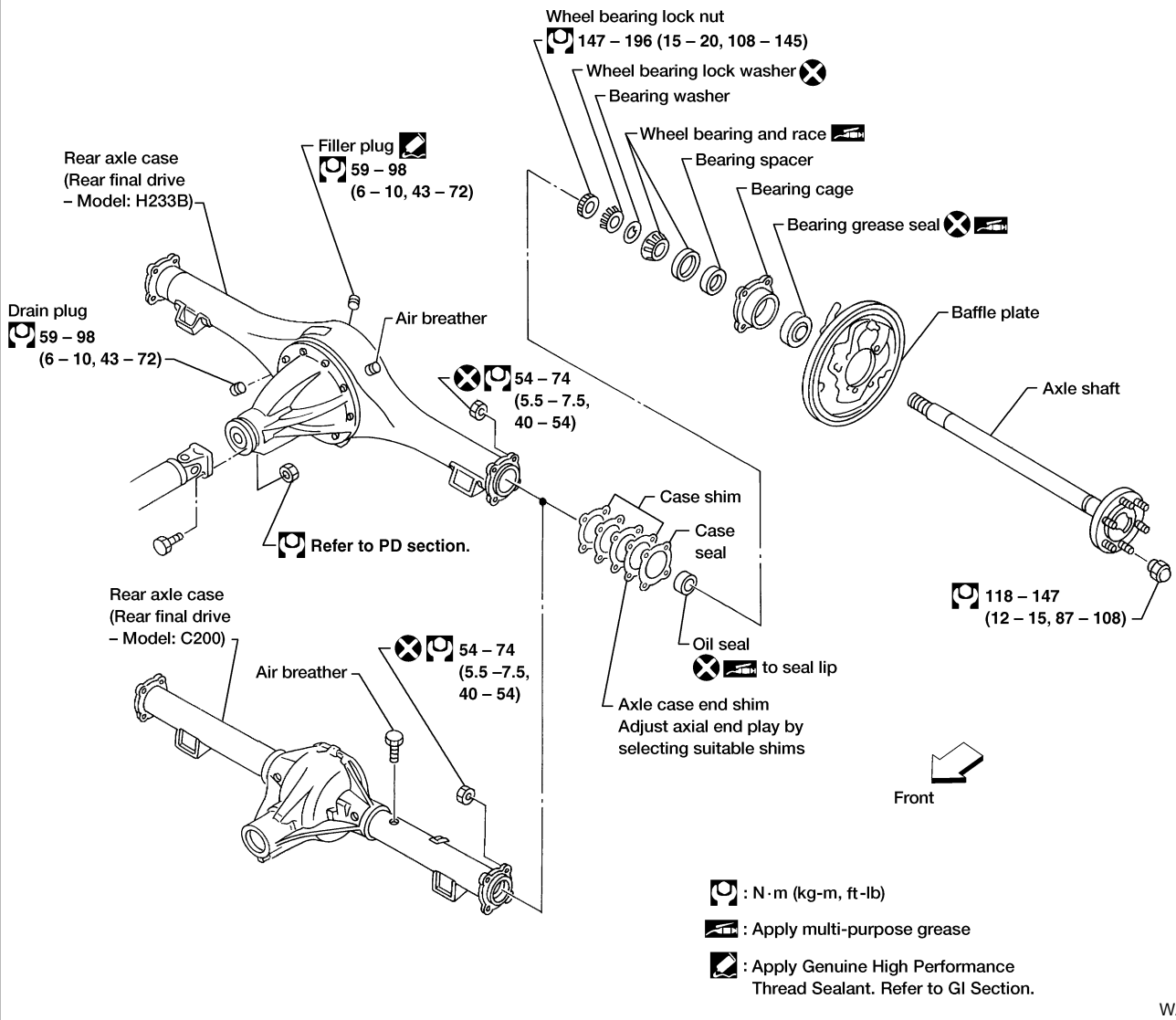

WAX032

GI
MA
EM
LC
EC
FE
CL
MT
AT
TF
PD
AX
SU
BR
ST
RS
BT
HA
SC
EL
IDX

REAR AXLE

Components (Cont'd)

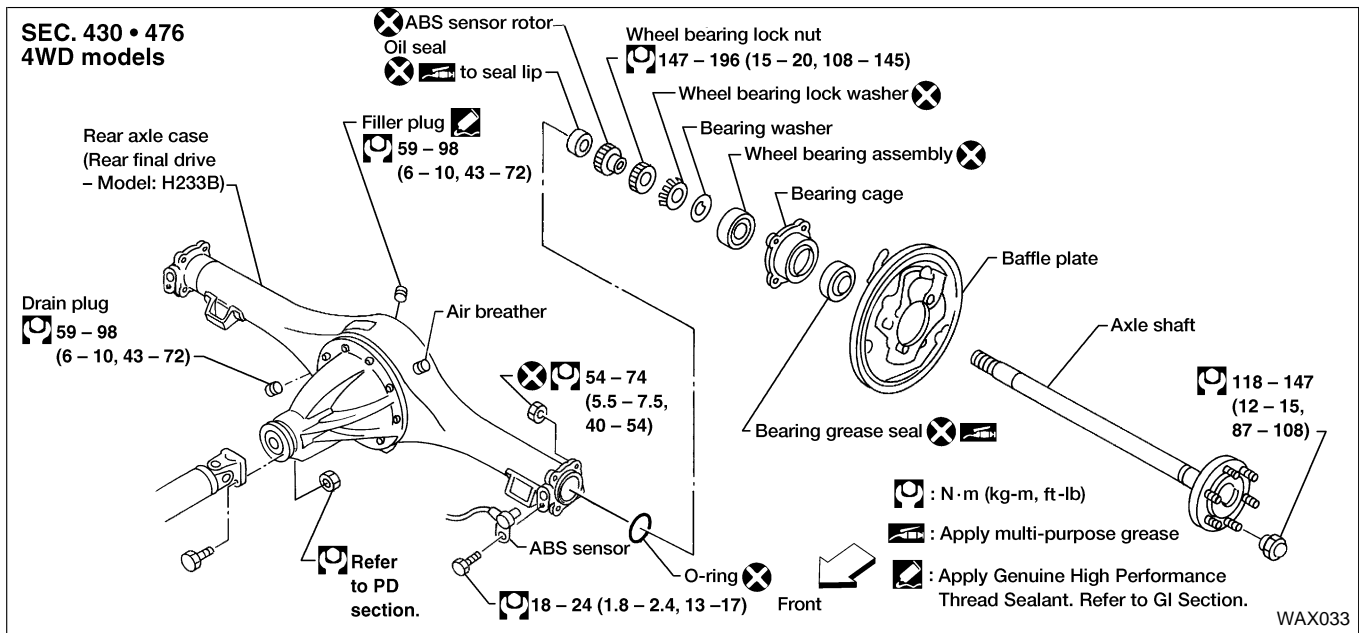

Removal

NGAX0034

- Before removing the rear axle, disconnect the ABS wheel sensor from the assembly. Then move it away from the axle. Failure to do so may result in damage to the sensor wires and the sensor becoming inoperative.
- Wheel bearing does not require maintenance.
- If growling noise is emitted from wheel bearing during operation, replace wheel bearing assembly.
- If the wheel bearing assembly is removed, it must be replaced. The old assembly must not be re-used.

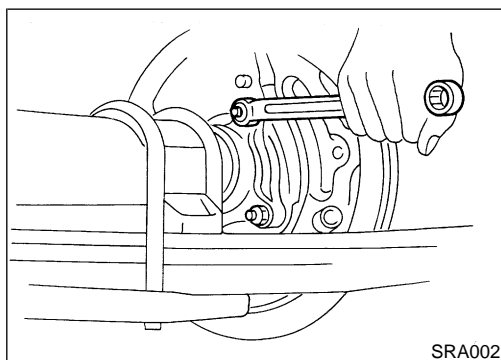

1. Disconnect parking brake cable and brake tube.
2. Remove nuts securing wheel bearing cage with baffle plate.

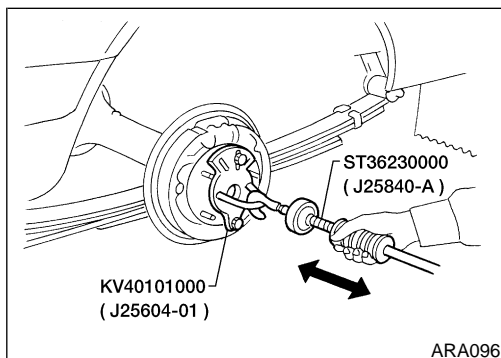

3. Draw out axle shaft with Tool.
4. Remove case shim and case seal (2WD models).
5. Remove O-ring (4WD models).
6. Remove oil seal.

Do not reuse oil seal once it is removed. Always install new one.

REAR AXLE

Removal (Cont'd)

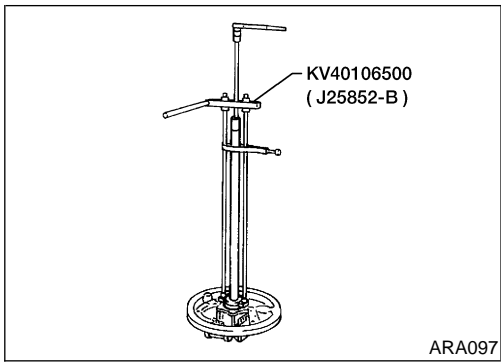

7. Remove ABS sensor rotor with tool (4WD models). Always replace sensor rotor with a new one.

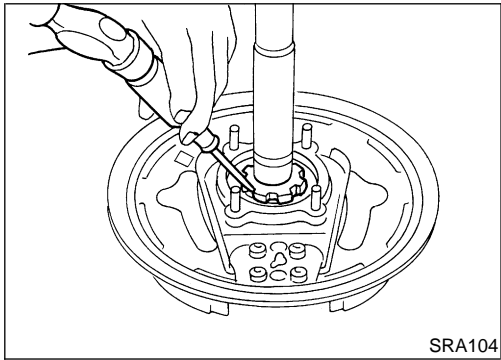

8. Unbend lock washer with suitable Tool.

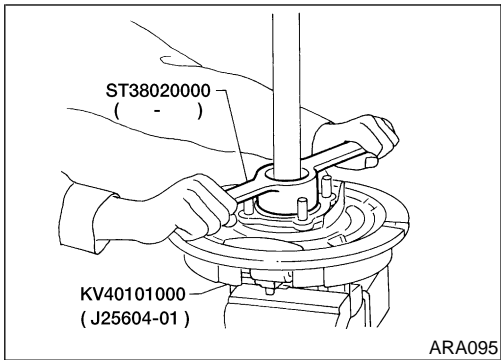

9. Remove bearing lock nut with Tool.

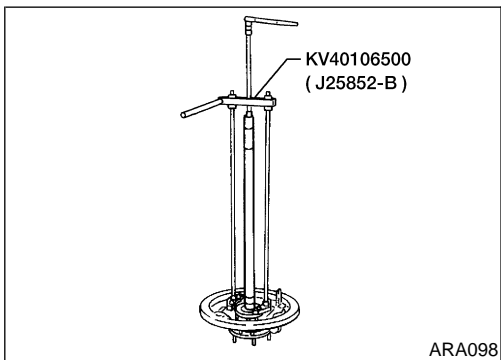

10. Remove wheel bearing together with bearing cage and baffle plate from axle shaft with Tool.

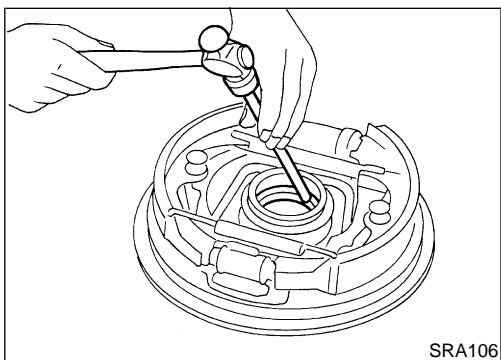

11. Remove grease seal in bearing cage with suitable bar.
12. Remove wheel bearing outer race with a brass drift (2WD models).

GI

MA

EM

LC

EC

FE

CL

MT

AT

TF

PD

AX

SU

BR

ST

RS

BT

HA

SC

EL

IDX

REAR AXLE

Removal (Cont'd)

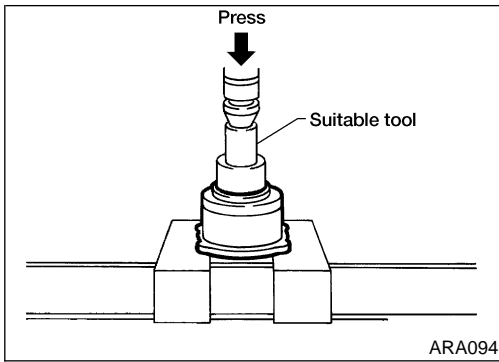

13. Remove wheel bearing assembly (4WD models).

Inspection

AXLE SHAFT

NGAX0035

- Check axle shaft for straightness, cracks, damage, wear and distortion. Replace if necessary.

NGAX0035S01

WHEEL BEARING

NGAX0035S02

- Make sure wheel bearing rolls freely and is free from noise, cracks, pitting and wear.

AXLE CASE

NGAX0035S03

- Check axle case for yield, deformation and cracks. Replace if necessary.

Installation

NGAX0036

2WD MODELS

NGAX0036S01

1. Install wheel bearing outer race with a brass drift.
2. Install a new grease seal in bearing cage.

After installing new grease seal, coat sealing lip with multi-purpose grease.

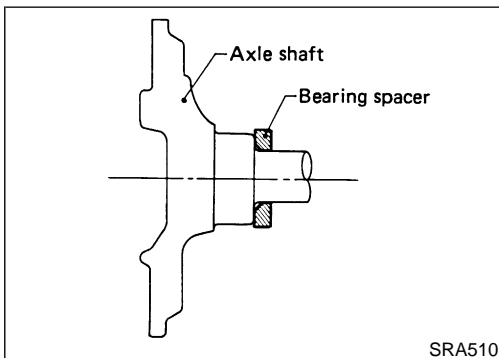
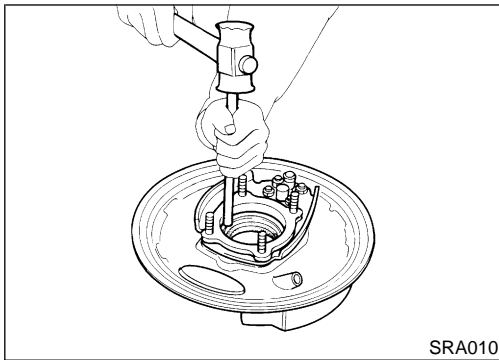

3. Install bearing spacer with chamfer side facing axle shaft flange.

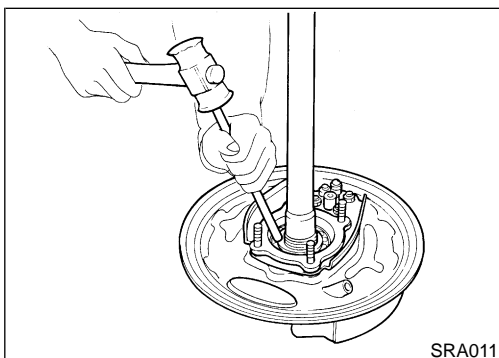

4. Install wheel bearing inner race with a brass drift.
5. Coat each bearing cone with multi-purpose grease.

Specified amount of grease:

8 - 12 g (0.28 - 0.42 oz)

REAR AXLE

Installation (Cont'd)

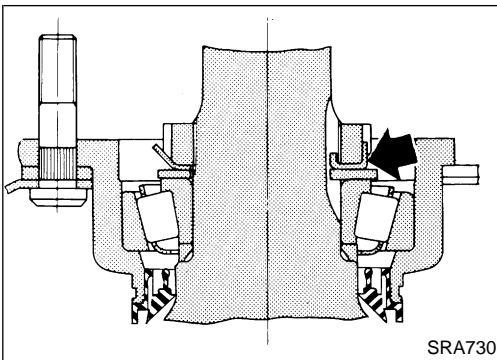

6. Install plain washer and a new wheel bearing lock washer.
7. Tighten wheel bearing lock nut.

Fit wheel bearing lock washer lip in wheel bearing lock nut groove correctly by tightening lock nut. Be sure to bend it up.

GI

MA

EM

LC

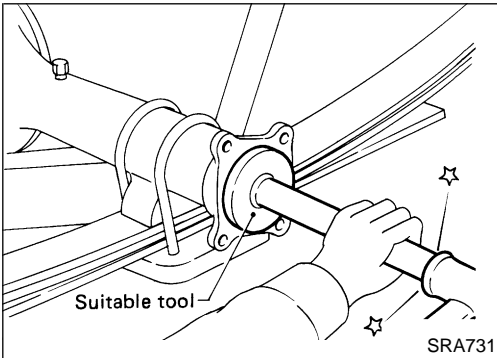

8. Install a new oil seal with suitable tool.

After installing new oil seal, coat sealing lip with multi-purpose grease.

EC

FE

CL

MT

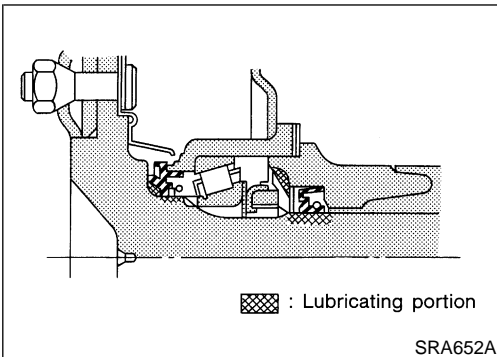

9. Apply recess of axle case end with multi-purpose grease.

10. Apply gear oil to the spline of axle shaft. Coat seal surface of axle shaft with multi-purpose grease (as shown left).

AT

TF

PD

AX

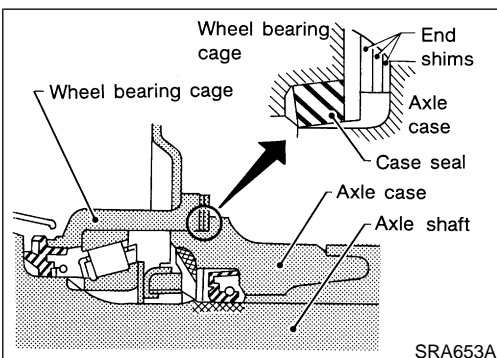

11. Adjust axial end play.

- a. Select end shims.

**Standard thickness including seal: 1.5 mm (0.059 in)
Axle case end shim: Refer to "WHEEL BEARING (REAR)", AX-38.**

Do not insert end shims between case seal and bearing cage.

SU

BR

ST

RS

- b. Insert axle shaft with Tool as a guide.

When inserting axle shaft, be careful not to damage oil seal.

- c. Measure end play of axle shaft.

Axial end play:

Servicing only one side of axle shaft

0.02 - 0.15 mm (0.0008 - 0.0059 in)

Servicing both side axle shafts

On first axle shaft (right or left) adjust axial end play

0.30 - 0.90 mm (0.0118 - 0.0354 in)

After servicing second axle shaft, total end play

BT

HA

SC

EL

IDX

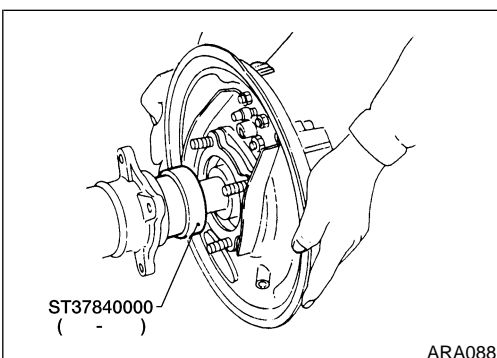

REAR AXLE

Installation (Cont'd)

0.02 - 0.15 mm (0.0008 - 0.0059 in)

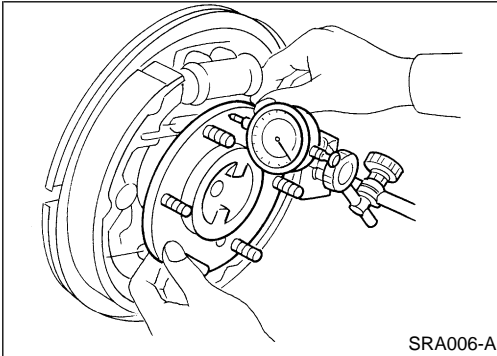

- d. If axial end play is not within the specified limit, reselect axle case end shims.
While adjusting axial end play, be careful not to damage oil seal.

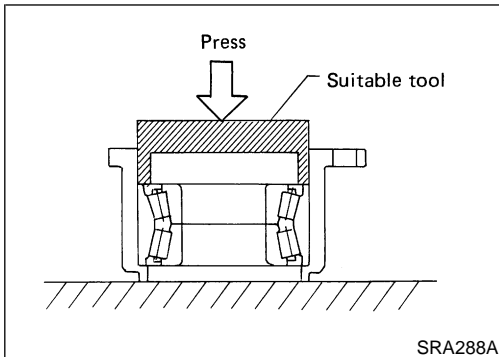

4WD MODELS

1. Press new wheel bearing until it bottoms end face of bearing cage. NGAX0036S02

Maximum load P:

78 kN (8 ton, 8.8 US ton, 7.9 Imp ton)

Always press outer race of wheel bearing during installation.

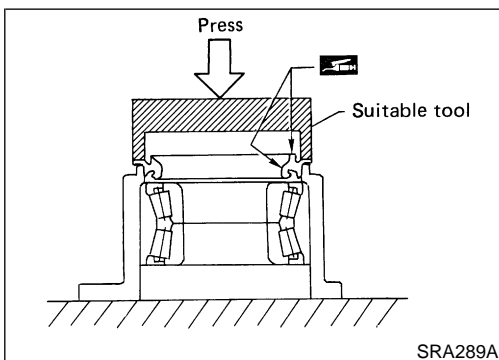

2. Press new grease seal until it bottoms end face of bearing cage.

After installing new grease seal, coat sealing lip with multi-purpose grease.

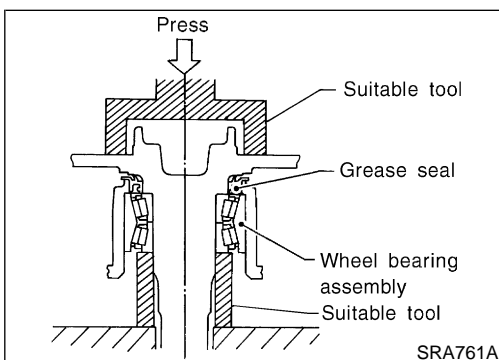

3. Press axle shaft into inner race of wheel bearing.

Maximum load P:

47.1 kN (4.8 ton, 5.3 US ton, 4.72 Imp ton)

Be careful not to damage or deform grease seal.

REAR AXLE

Installation (Cont'd)

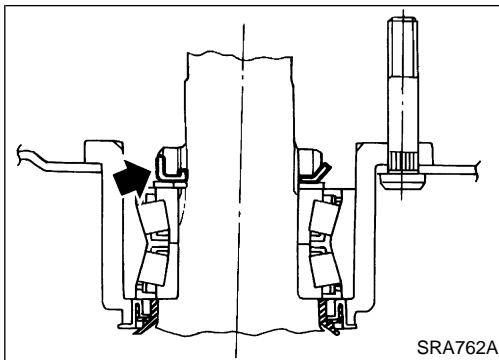

4. Install plain washer and a new wheel bearing lock washer.
5. Tighten wheel bearing lock nut to specified torque.

 : 147 - 196 N·m (15 - 20 kg·m, 108 - 145 ft·lb)

Fit wheel bearing lock washer lip in wheel bearing lock nut groove correctly by tightening lock nut. Be sure to bend it up.

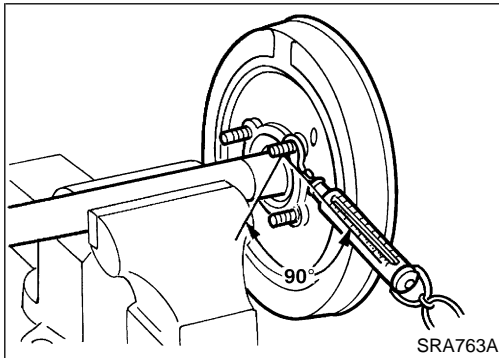

6. Check wheel bearing preload.
 - a. Turn bearing cage (with respect to axle shaft) two or three times. It must turn smoothly.
 - b. Attach spring gauge to bearing cage bolt (as shown at left) and pull it at a speed of 10 rpm to measure preload.

Spring gauge indication:

6.9 - 48.1 N (0.7 - 4.9 kg, 1.5 - 10.8 lb)

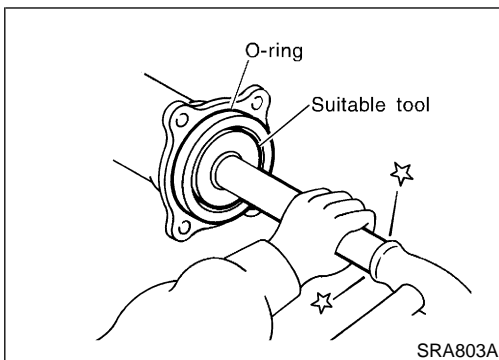

7. Install new oil seal to rear axle housing using a suitable tool.
After installing new oil seal, coat sealing lip with multi-purpose grease.

8. Install new O-ring to rear axle housing.

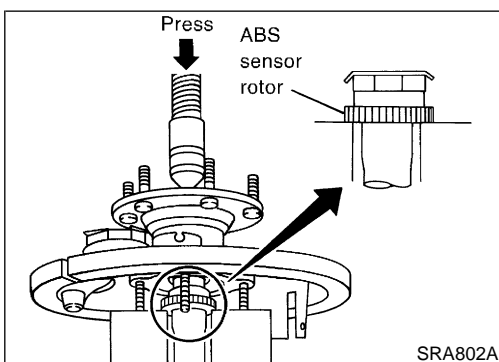

9. Press ABS sensor rotor onto axle shaft until it contacts wheel bearing lock nut. Always replace sensor rotor with new one.

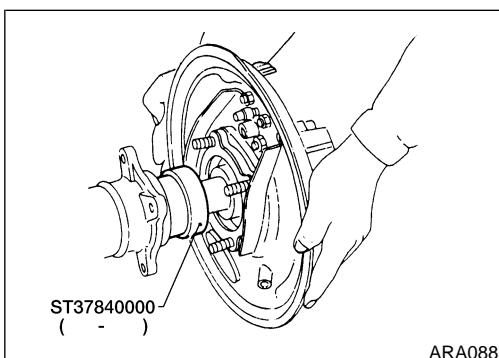

10. Position axle shafts in rear axle housing with Tool as a guide.
Be careful not to damage oil seal.

GI

MA

EM

LC

EC

FE

CL

MT

AT

TF

PD

AX

SU

BR

ST

RS

BT

HA

SC

EL

IDX

REAR AXLE

Installation (Cont'd)

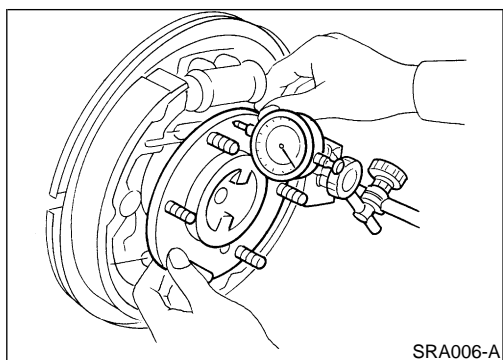

11. Check axial end play.
 - a. Check that wheel bearings operate smoothly.
 - b. Check axial end play.

**Axial end play:
0 mm (0 in)**

Service Data and Specifications (SDS)

WHEEL BEARING (REAR)

2WD Models

NGAX0037

NGAX0037S01

Total end play mm (in)	0.02 - 0.15 (0.0008 - 0.0059)	
Available rear axle case end shims	Thickness mm (in)	Part number*
	0.05 (0.0020)	43086-P0110
	0.07 (0.0028)	43087-P0110
	0.10 (0.0039)	43088-P0110
	0.15 (0.0059)	43086-B9500
	0.20 (0.0079)	43089-P0110
	0.50 (0.0197) 1.00 (0.0394)	43090-P0110 43036-01G00

*: Always check with the Parts Department for the latest parts information.

4WD Models

NGAX0037S02

Total end play mm (in)	0 (0)
Wheel bearing preload at bearing cage bolt N (kg, lb)	6.9 - 48.1 (0.7 - 4.9, 1.5 - 10.8)